

WEBENCH® Design Report

Design : 3612920/12 LM3429MH/NOPB
 LM3429MH/NOPB 5.0V-15.0V to 37.73V @ 1.3279469892473117A

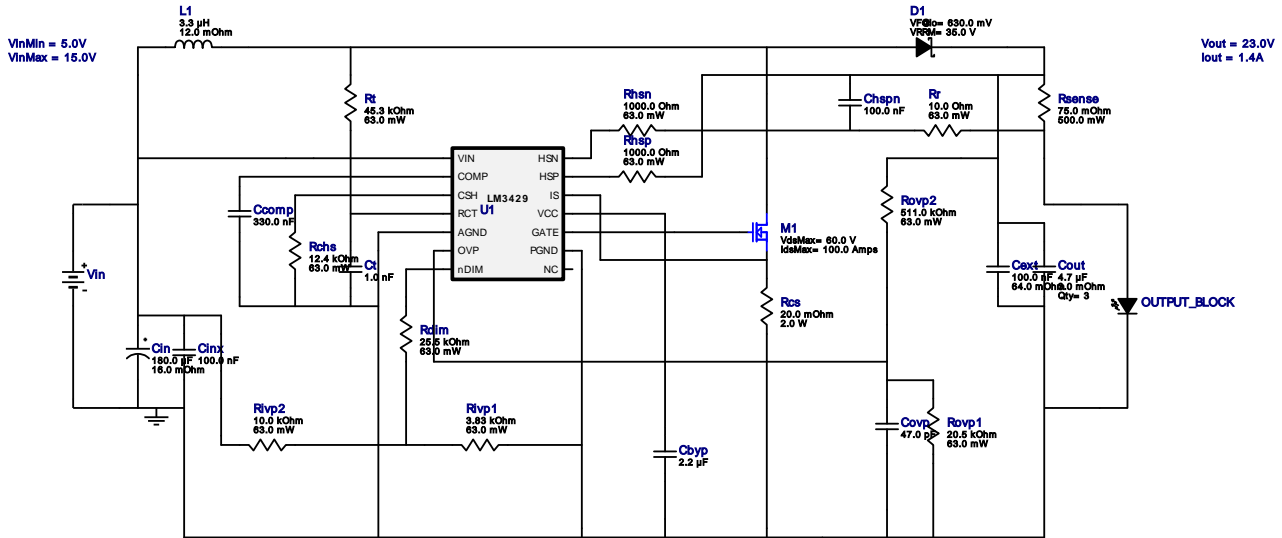

1. This regulator device is qualified for Automotive applications. All passives and other components selected in this design may not be qualified for Automotive applications. The user is required to verify that all components in the design meet the qualification and safety requirements for their specific application. View WEBENCH(R) Disclaimer.

Electrical BOM

#	Name	Manufacturer	Part Number	Properties	Qty	Price	Footprint
1.	Cbyp	Taiyo Yuden	EMK212B7225KG-T Series= X7R	Cap= 2.2 uF VDC= 16.0 V IRMS= 0.0 A	1	\$0.03	0805 7 mm ²
2.	Ccomp	MuRata	GRM155R61A334KE15D Series= X5R	Cap= 330.0 nF VDC= 10.0 V IRMS= 0.0 A	1	\$0.01	0402 3 mm ²
3.	Cext	Kemet	C0805C104K5RACTU Series= X7R	Cap= 100.0 nF ESR= 64.0 mOhm VDC= 50.0 V IRMS= 1.64 A	1	\$0.01	0805 7 mm ²
4.	Chspn	MuRata	GRM21BR71E104KA01L Series= X7R	Cap= 100.0 nF VDC= 25.0 V IRMS= 0.0 A	1	\$0.01	0805 7 mm ²
5.	Cin	Panasonic	25SVPF180M Series= 1273	Cap= 180.0 uF ESR= 16.0 mOhm VDC= 25.0 V IRMS= 4.65 A	1	\$0.61	CAPSMT_62_E12 106 mm ²
6.	Cinx	Kemet	C0603C104K5RACTU Series= X7R	Cap= 100.0 nF VDC= 50.0 V IRMS= 0.0 A	1	\$0.01	0603 5 mm ²
7.	Cout	MuRata	GRM31CR71H475KA12L Series= X7R	Cap= 4.7 uF ESR= 3.0 mOhm VDC= 50.0 V IRMS= 4.98 A	3	\$0.07	1206 11 mm ²
8.	Covp	Kemet	C0805C470K5GACTU Series= C0G/NP0	Cap= 47.0 pF VDC= 50.0 V IRMS= 0.0 A	1	\$0.01	0805 7 mm ²

#	Name	Manufacturer	Part Number	Properties	Qty	Price	Footprint
9.	Ct	Yageo America	CC0805JRNPO9BN102 Series= C0G/NP0	Cap= 1.0 nF VDC= 50.0 V IRMS= 0.0 A	1	\$0.01	 0805 7 mm ²
10.	D1	Vishay-Semiconductor	MBRB1635PBF	VF@Io= 630.0 mV VRRM= 35.0 V	1	\$0.71	 DDPAK 210 mm ²
11.	D_LED	Cree	XHP50A-00-0000-0D00J40E1LED		4	\$6.54	 xlampxhp 0 mm ²
12.	L1	Bourns	SRP1235-3R3M	L= 3.3 µH DCR= 12.0 mOhm	1	\$0.53	 SRP1235 253 mm ²
13.	M1	Texas Instruments	CSD18532Q5B	VdsMax= 60.0 V IdsMax= 100.0 Amps	1	\$1.14	 TRANS_NexFET_Q5B 58 mm ²
14.	Rchs	Vishay-Dale	CRCW040212K4FKED Series= CRCW..e3	Res= 12.4 kOhm Power= 63.0 mW Tolerance= 1.0%	1	\$0.01	 0402 3 mm ²
15.	Rcs	Stackpole Electronics Inc	CSRN2512FK20L0 Series= ?	Res= 20.0 mOhm Power= 2.0 W Tolerance= 1.0%	1	\$0.15	 2512 43 mm ²
16.	Rdim	Vishay-Dale	CRCW040225K5FKED Series= CRCW..e3	Res= 25.5 kOhm Power= 63.0 mW Tolerance= 1.0%	1	\$0.01	 0402 3 mm ²
17.	Rhsn	Vishay-Dale	CRCW04021K00FKED Series= CRCW..e3	Res= 1000.0 Ohm Power= 63.0 mW Tolerance= 1.0%	1	\$0.01	 0402 3 mm ²
18.	Rhsp	Vishay-Dale	CRCW04021K00FKED Series= CRCW..e3	Res= 1000.0 Ohm Power= 63.0 mW Tolerance= 1.0%	1	\$0.01	 0402 3 mm ²
19.	Rivp1	Vishay-Dale	CRCW04023K83FKED Series= CRCW..e3	Res= 3.83 kOhm Power= 63.0 mW Tolerance= 1.0%	1	\$0.01	 0402 3 mm ²
20.	Rivp2	Vishay-Dale	CRCW040210K0FKED Series= CRCW..e3	Res= 10.0 kOhm Power= 63.0 mW Tolerance= 1.0%	1	\$0.01	 0402 3 mm ²
21.	Rovp1	Vishay-Dale	CRCW040220K5FKED Series= CRCW..e3	Res= 20.5 kOhm Power= 63.0 mW Tolerance= 1.0%	1	\$0.01	 0402 3 mm ²
22.	Rovp2	Vishay-Dale	CRCW0402511KFKED Series= CRCW..e3	Res= 511.0 kOhm Power= 63.0 mW Tolerance= 1.0%	1	\$0.01	 0402 3 mm ²
23.	Rr	Vishay-Dale	CRCW040210R0FKED Series= CRCW..e3	Res= 10.0 Ohm Power= 63.0 mW Tolerance= 1.0%	1	\$0.01	 0402 3 mm ²
24.	Rsense	Stackpole Electronics Inc	CSR1206FK75L0 Series= ?	Res= 75.0 mOhm Power= 500.0 mW Tolerance= 1.0%	1	\$0.10	 1206 11 mm ²
25.	Rt	Vishay-Dale	CRCW040245K3FKED Series= CRCW..e3	Res= 45.3 kOhm Power= 63.0 mW Tolerance= 1.0%	1	\$0.01	 0402 3 mm ²

#	Name	Manufacturer	Part Number	Properties	Qty	Price	Footprint
26.	U1	Texas Instruments	LM3429MH/NOPB	Switcher	1	\$1.20	 MXA14A 59 mm ²

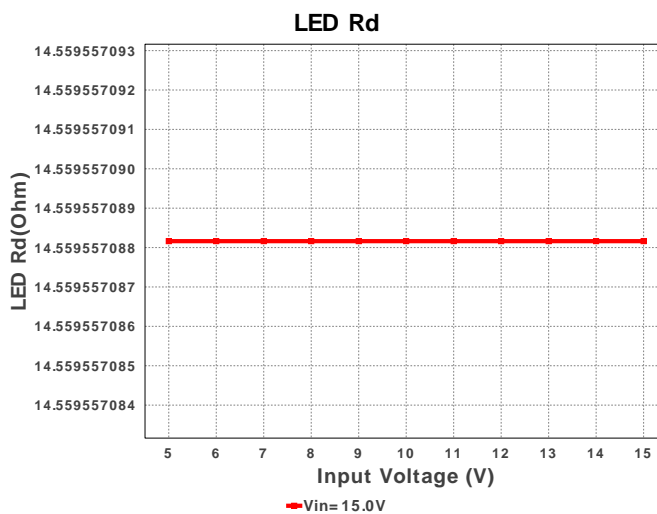
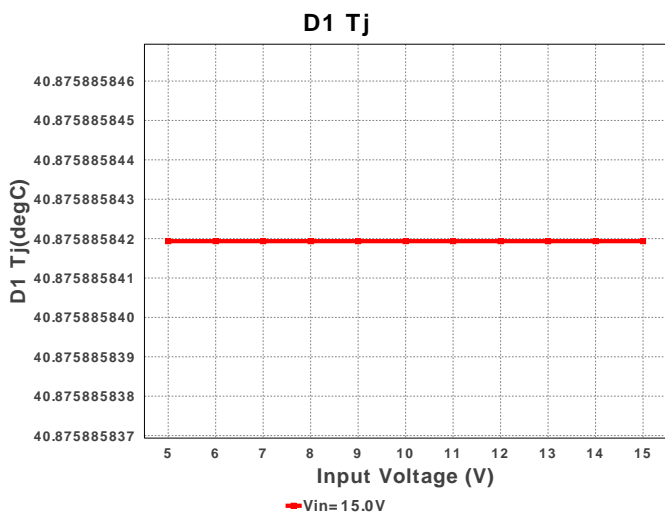
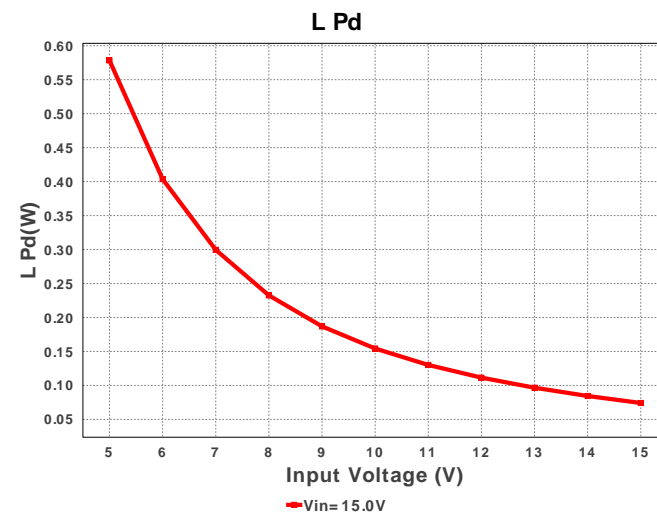
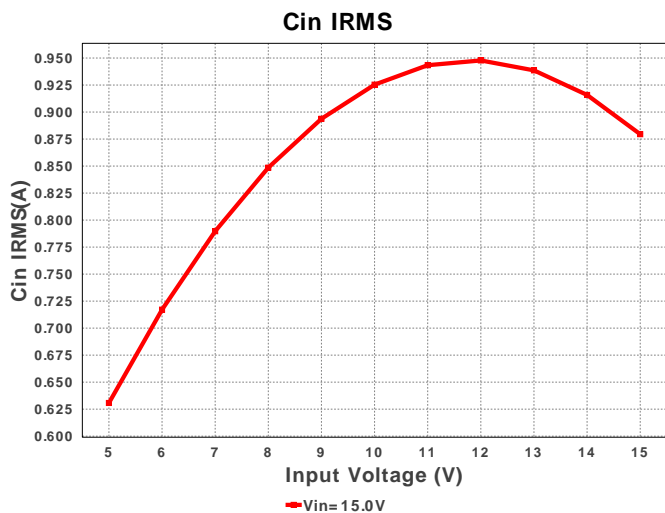
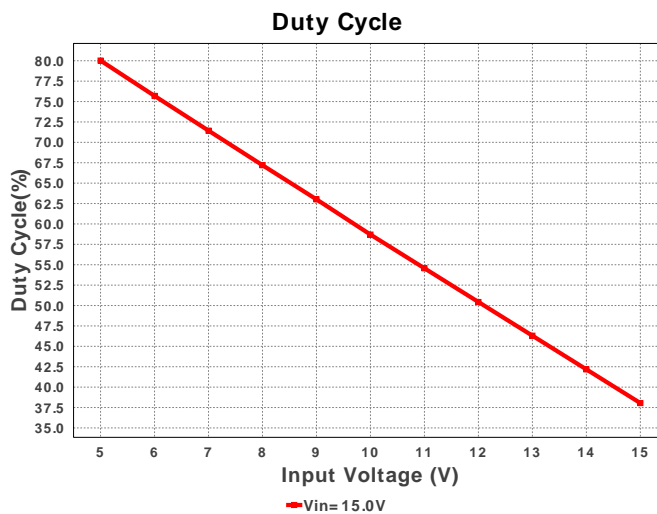
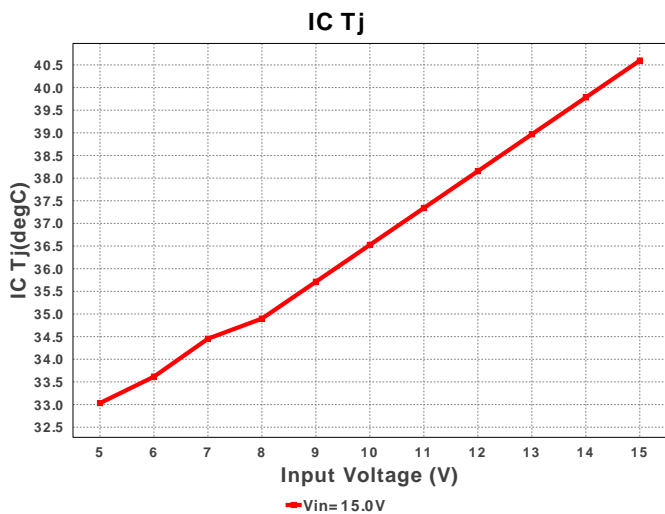

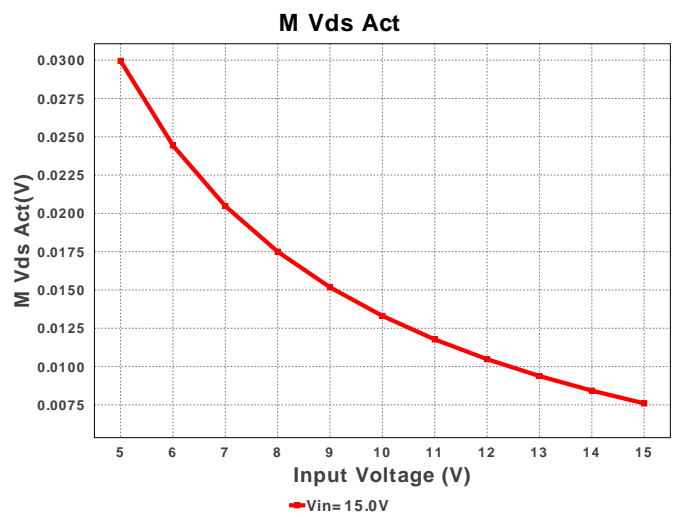
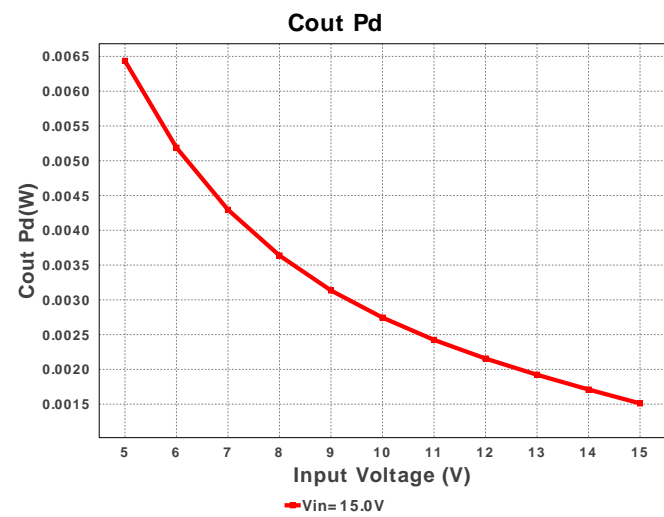
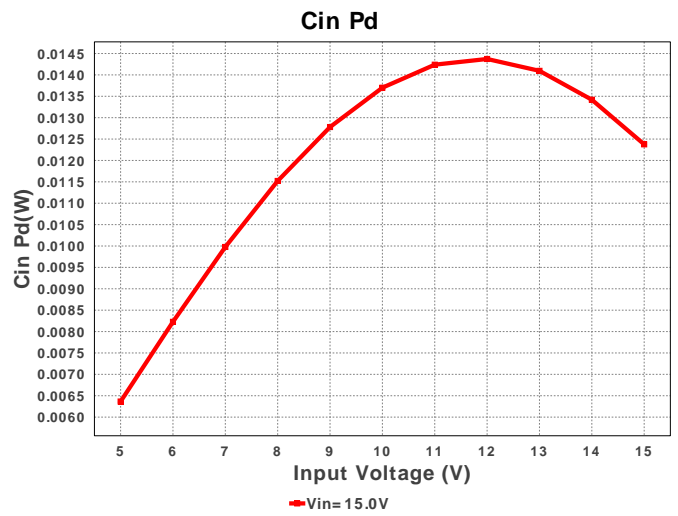
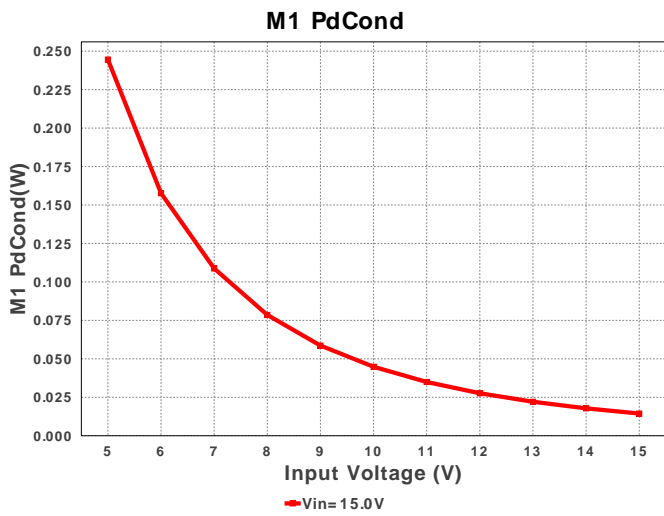
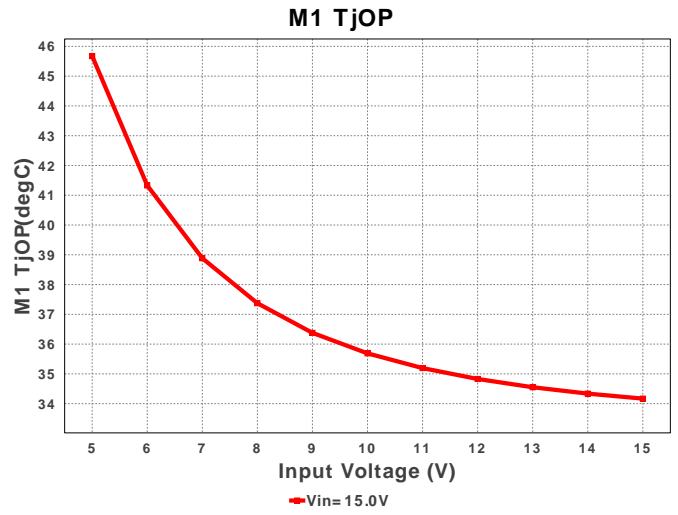
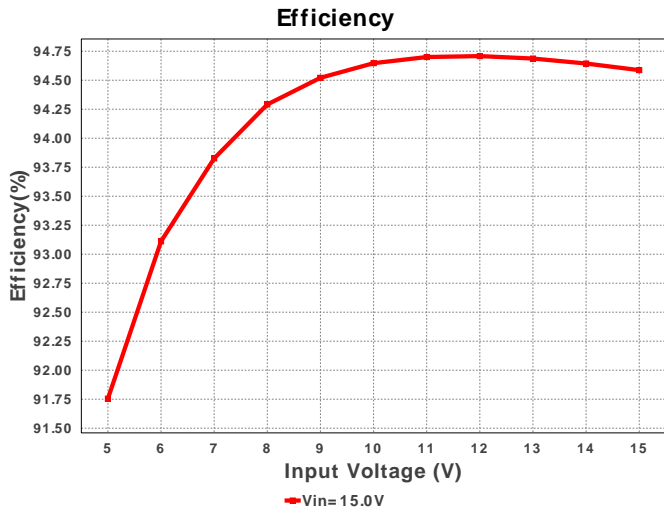

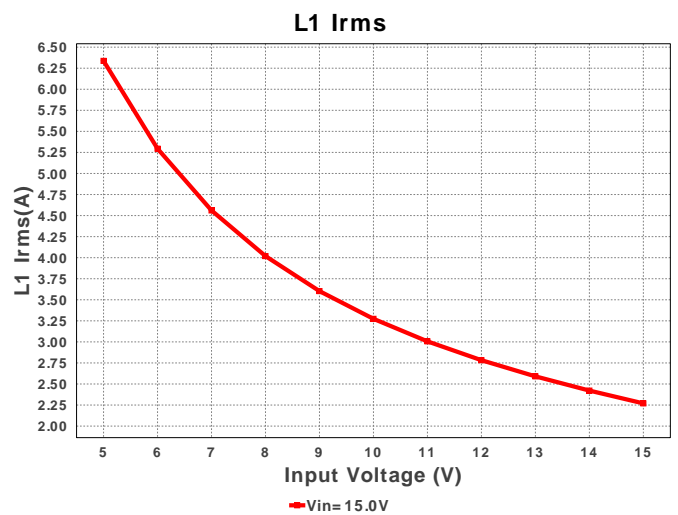
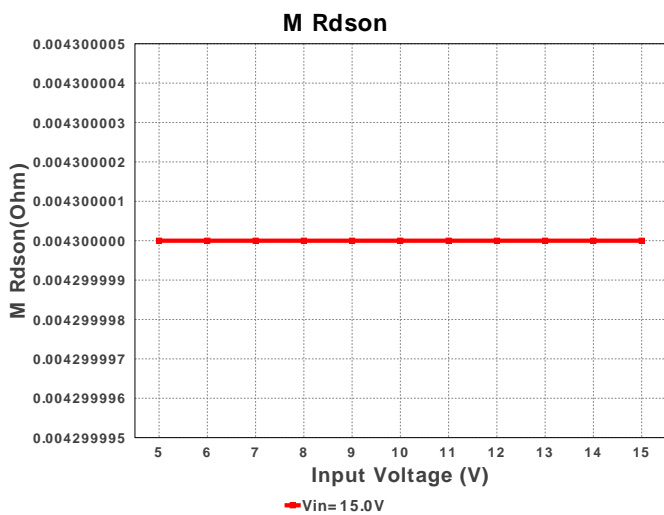
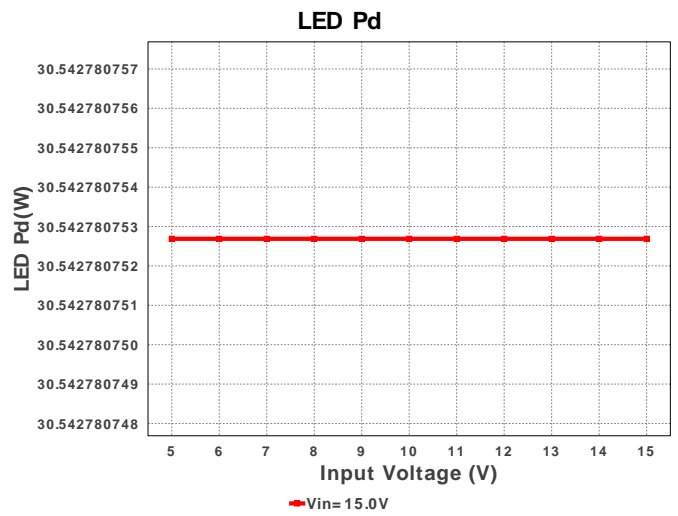
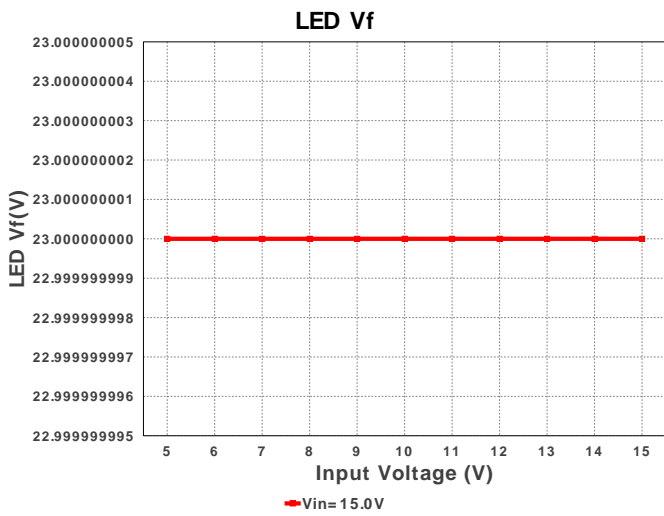
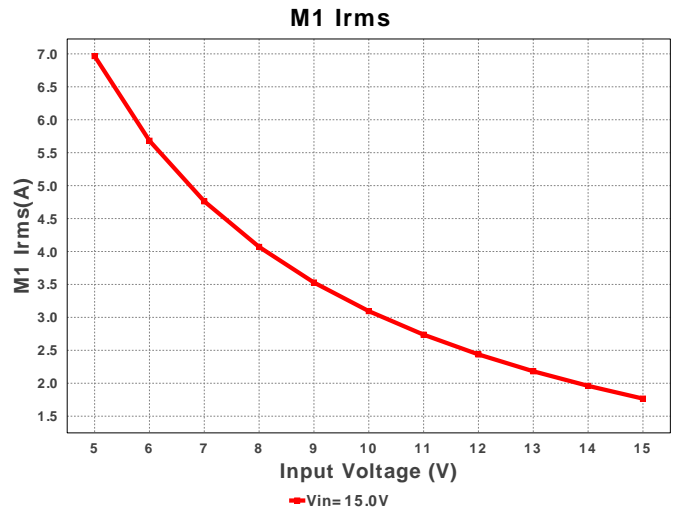
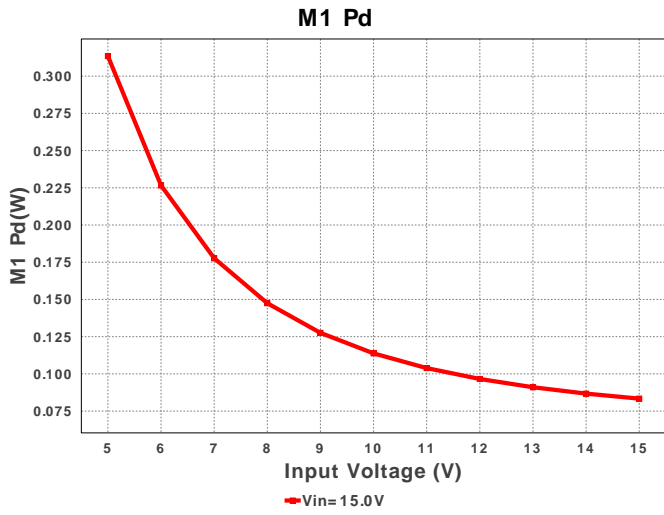

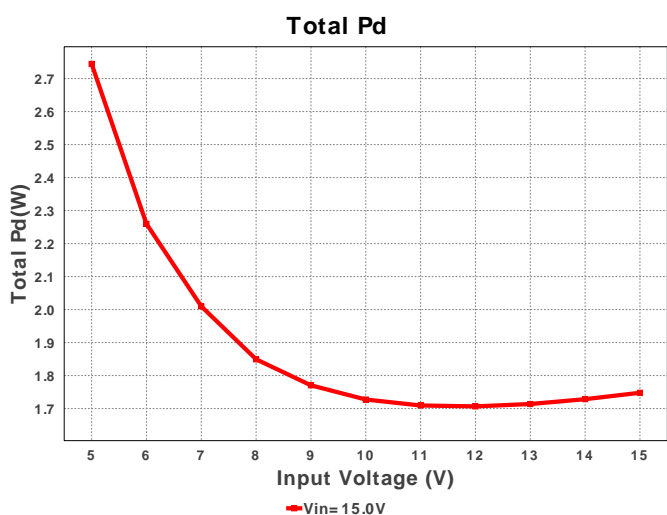
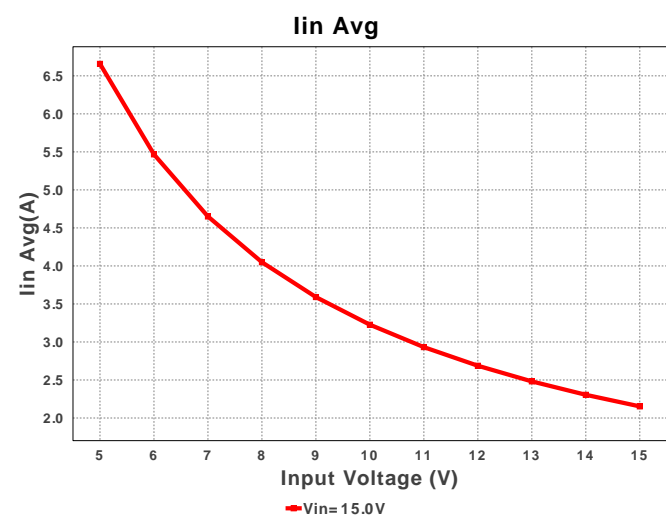
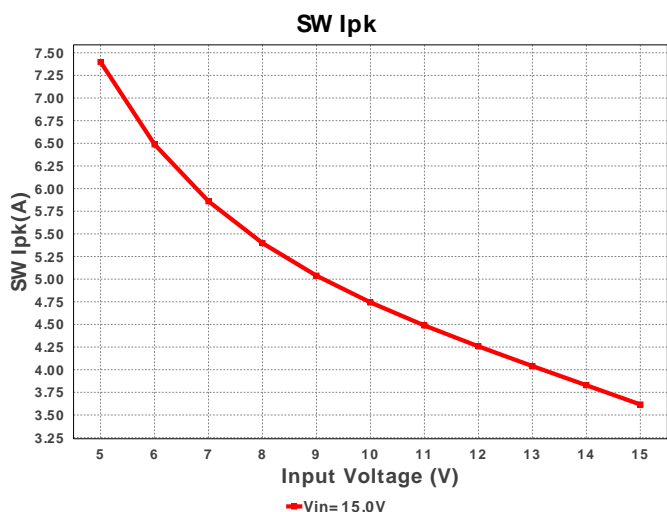
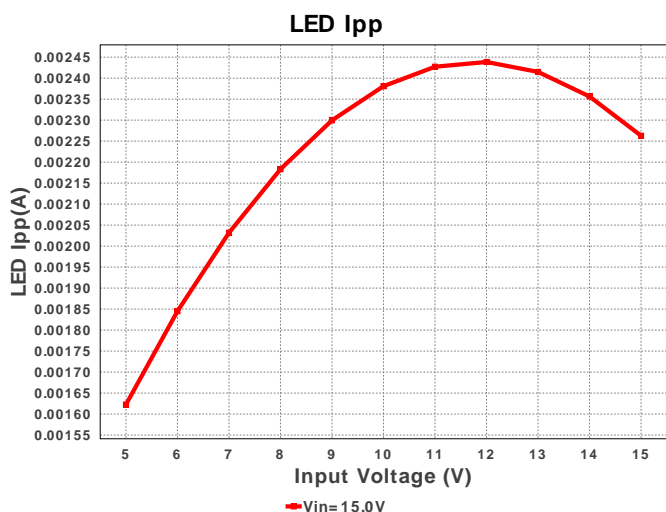
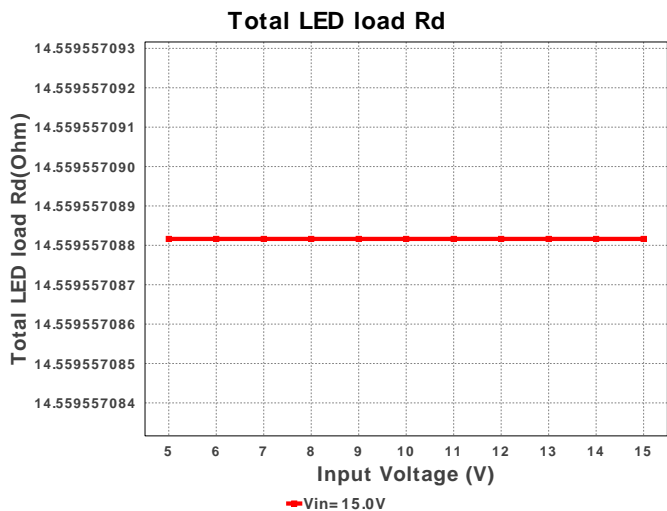
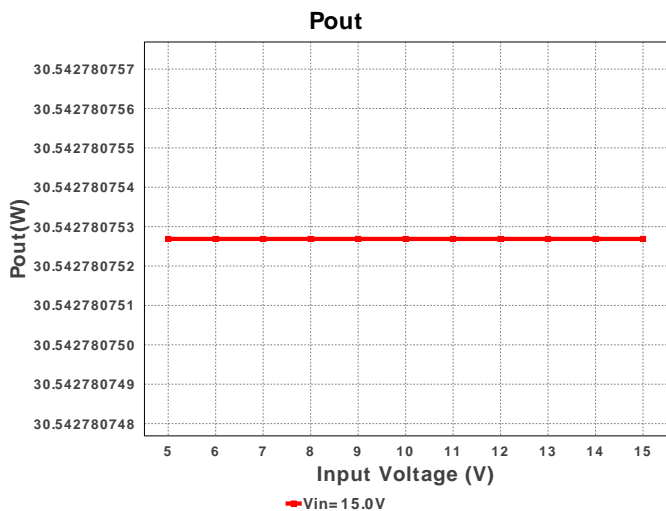

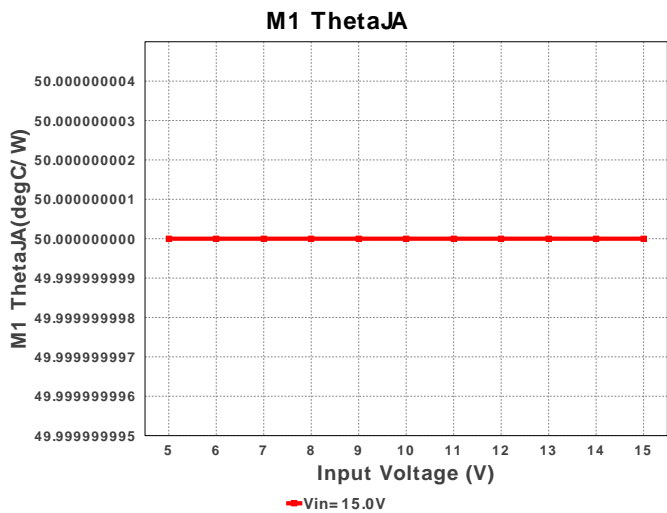
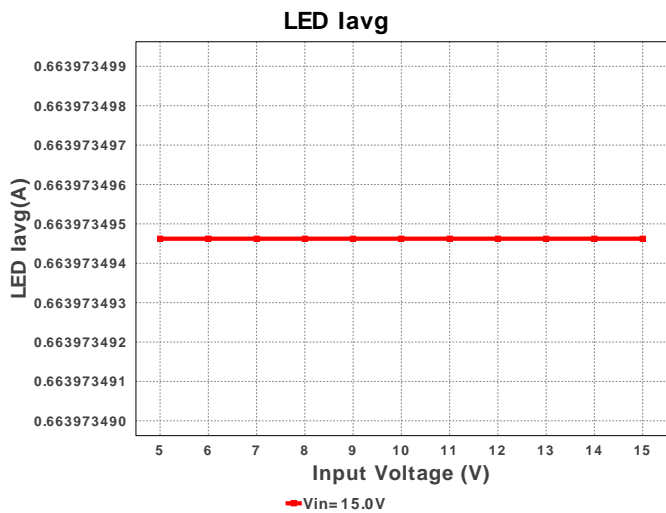
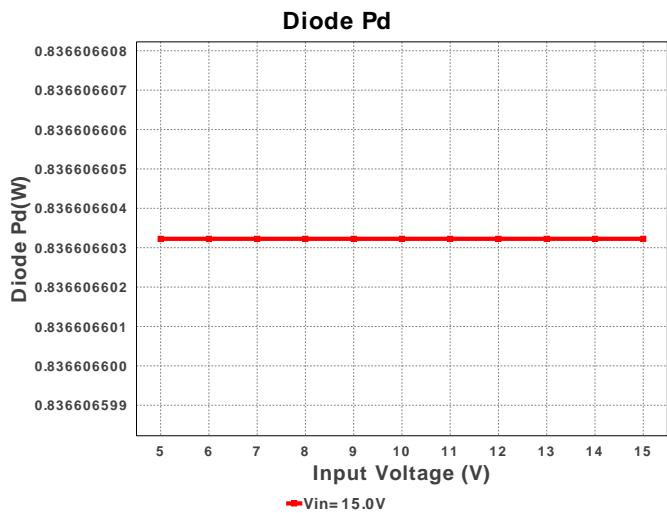
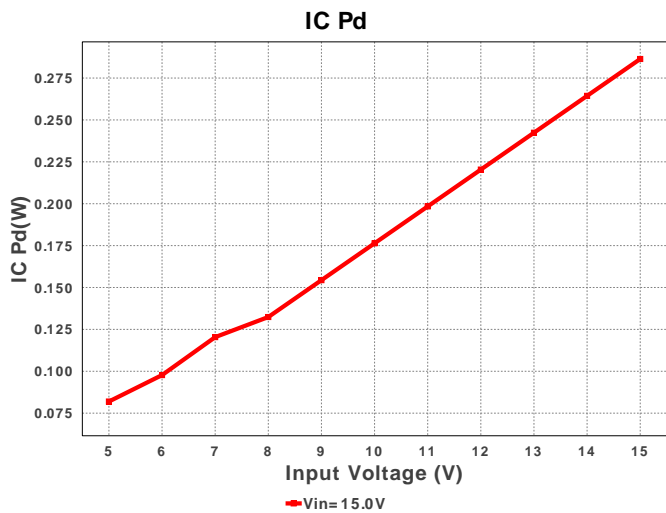
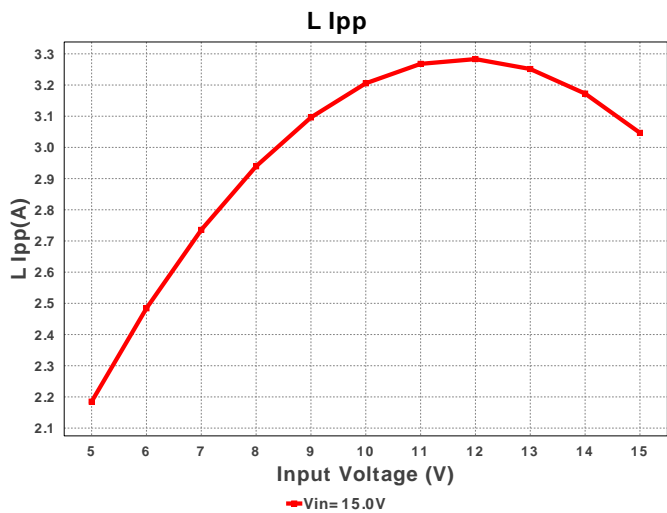
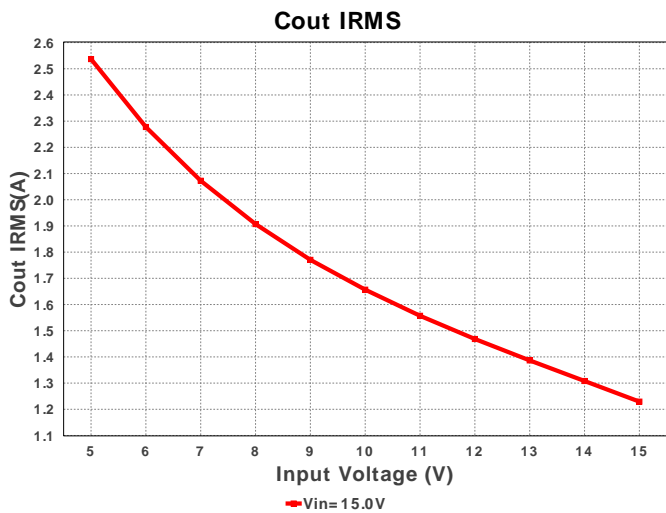

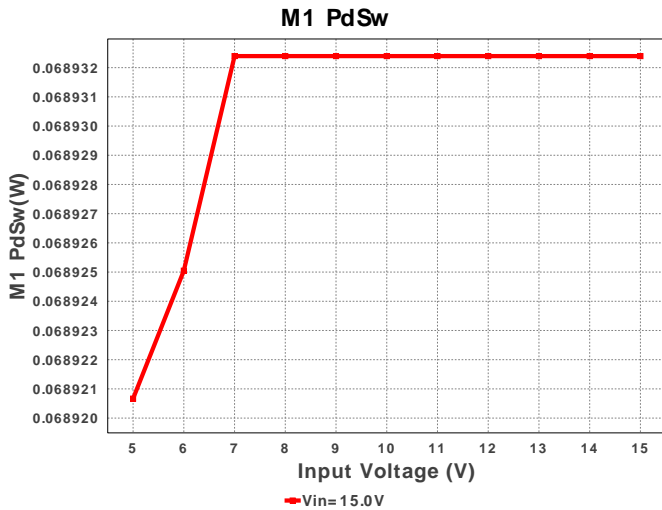

Operating Values

#	Name	Value	Category	Description
1.	Cin IRMS	688.966 mA	Current	Input capacitor RMS ripple current
2.	Cout IRMS	3.346 A	Current	Output capacitor RMS ripple current
3.	Iin Avg	11.274 A	Current	Average input current
4.	L Ipp	2.387 A	Current	Peak-to-peak inductor ripple current
5.	L1 Irms	10.356 A	Current	Inductor ripple current
6.	LED Iavg	663.973 mA	Current	LED Average Current
7.	LED Ipp	1.773 mA	Current	LED Ripple Current
8.	M1 Irms	11.863 A	Current	M1 MOSFET Irms
9.	SW Ipk	11.527 A	Current	Peak switch current
10.	BOM Count	31	General	Total Design BOM count
11.	FootPrint	843.0 mm ²	General	Total Foot Print Area of BOM components
12.	Frequency	546.358 kHz	General	Switching frequency
13.	IC Tolerance	25.0 mV	General	IC Feedback Tolerance
14.	M Rdson	6.8 mOhm	General	Drain-Source On-resistance
15.	M Vds Act	80.668 mV	General	M Vds
16.	M1 ThetaJA	50.0 degC/W	General	MOSFET junction-to-ambient thermal resistance
17.	Pout	50.097 W	General	Total output power
18.	Total BOM	\$31.0	General	Total BOM Cost
19.	D1 Tj	40.876 degC	Op_Point	D1 junction temperature
20.	Vout OP	37.725 V	Op_Point	Operational Output Voltage
21.	Duty Cycle	88.163 %	Op_point	Duty cycle
22.	Efficiency	88.873 %	Op_point	Steady state efficiency
23.	IC Tj	33.36 degC	Op_point	IC junction temperature
24.	ICThetaJA	37.0 degC/W	Op_point	IC junction-to-ambient thermal resistance
25.	IOUT_OP	1.328 A	Op_point	Iout operating point
26.	LED Rd	14.56 Ohm	Op_point	LED DynamicResistance
27.	LED Vf	37.725 V	Op_point	Total LED Forward Calculated Voltage
28.	M1 TjOP	96.949 degC	Op_point	M1 MOSFET junction temperature
29.	VIN_OP	5.0 V	Op_point	Vin operating point
30.	Cin Pd	7.595 mW	Power	Input capacitor power dissipation
31.	Cout Pd	11.199 mW	Power	Output capacitor power dissipation
32.	Diode Pd	836.607 mW	Power	Diode power dissipation
33.	IC Pd	90.808 mW	Power	IC power dissipation
34.	L Pd	1.544 W	Power	Inductor power dissipation
35.	LED Pd	50.097 W	Power	LED Power Dissipation
36.	M1 Pd	1.339 W	Power	M1 MOSFET total power dissipation
37.	M1 PdCond	1.232 W	Power	M1 MOSFET conduction losses
38.	M1 PdSw	106.597 mW	Power	M1 MOSFET switching losses
39.	Total Pd	6.272 W	Power	Total Power Dissipation
40.	Total LED load Rd	14.56 Ohm	Unknown	Total LED Load DynamicResistance

Design Inputs

#	Name	Value	Description
1.	Iout	1.4	Maximum Output Current
2.	Iout1	1.4	Output Current #1
3.	VinMax	15.0	Maximum input voltage
4.	VinMin	5.0	Minimum input voltage
5.	Vout	23.0	Output Voltage
6.	Vout1	23.0	Output Voltage #1
7.	application	LED_DRIVER	LED Application
8.	base_pn	LM3429	Texas Instruments Base Part Number

#	Name	Value	Description
9.	isLEDArchitect	N	LED Architect Project
10.	ledparallel	2.0	Number of LED in parallel
11.	ledpartnumber	XHP50A-00-0000-0D00	LED Part number
12.	ledseries	2.0	Number of LED in series
13.	line_fsw	60.0	AC Line Frequency
14.	source	DC	Input Source Type
15.	ta	30.0	Ambient temperature

Design Assistance

1. LM3429 Product Folder : <http://www.ti.com/product/LM3429> : contains the data sheet and other resources.

Texas Instruments' WEBENCH simulation tools attempt to recreate the performance of a substantially equivalent physical implementation of the design. Simulations are created using Texas Instruments' published specifications as well as the published specifications of other device manufacturers. While Texas Instruments does update this information periodically, this information may not be current at the time the simulation is built. Texas Instruments does not warrant the accuracy or completeness of the specifications or any information contained therein. Texas Instruments does not warrant that any designs or recommended parts will meet the specifications you entered, will be suitable for your application or fit for any particular purpose, or will operate as shown in the simulation in a physical implementation. Texas Instruments does not warrant that the designs are production worthy.

You should completely validate and test your design implementation to confirm the system functionality for your application prior to production.

Use of Texas Instruments' WEBENCH simulation tools is subject to [Texas Instruments' Site Terms and Conditions of Use](#). Prototype boards based on WEBENCH created designs are provided AS IS without warranty of any kind for evaluation and testing purposes and are subject to the terms of the [Evaluation License Agreement](#).