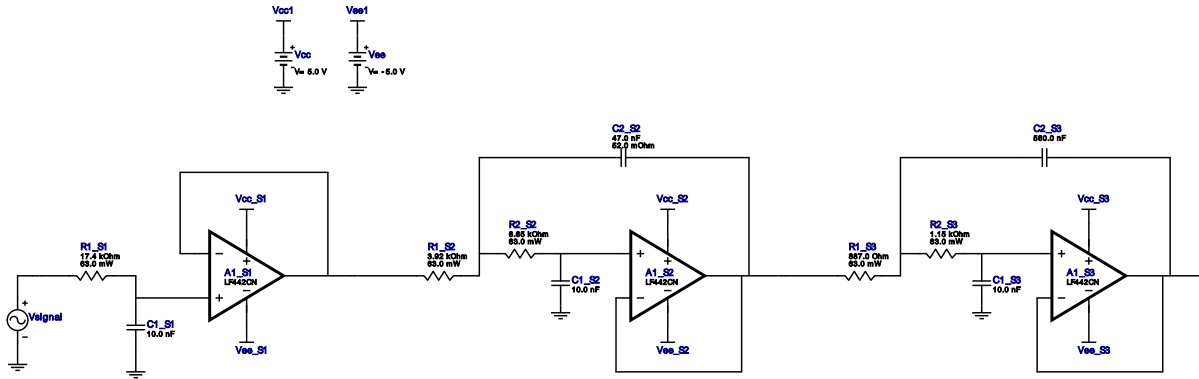

WEBENCH® Design Report

 Design : 3778301/5 LF442CN
 Lowpass, Sallen Key, Chebyshev 0.2 dB

Electrical BOM

#	Name	Manufacturer	Part Number	Properties	Qty	Price	Footprint
1.	A1_S1	Texas Instruments	LF442CN	GbwTyp= 1.0 MHz VccMin= 6.0 V VccMax= 36.0 V	1	\$0.55	DIP 0 mm ²
2.	A1_S2	Texas Instruments	LF442CN	GbwTyp= 1.0 MHz VccMin= 6.0 V VccMax= 36.0 V	1	\$0.55	DIP 0 mm ²
3.	A1_S3	Texas Instruments	LF442CN	GbwTyp= 1.0 MHz VccMin= 6.0 V VccMax= 36.0 V	1	\$0.55	DIP 0 mm ²
4.	C1_S1	Kemet	C0603C103J5RACTU Series= X7R	Cap= 10.0 nF VDC= 50.0 V Tolerance= 5.0 %	1	\$0.01	0603 5 mm ²
5.	C1_S2	Kemet	C0603C103J5RACTU Series= X7R	Cap= 10.0 nF VDC= 50.0 V Tolerance= 5.0 %	1	\$0.01	0603 5 mm ²
6.	C1_S3	Kemet	C0603C103J5RACTU Series= X7R	Cap= 10.0 nF VDC= 50.0 V Tolerance= 5.0 %	1	\$0.01	0603 5 mm ²
7.	C2_S2	AVX	06033C473JAT2A Series= X7R	Cap= 47.0 nF ESR= 52.0 mOhm VDC= 25.0 V Tolerance= 5.0 %	1	\$0.09	0603 5 mm ²
8.	C2_S3	CUSTOM	CUSTOM Series= ?	Cap= 560.0 nF VDC= 0.0 V Tolerance= 0.0 %	1	NA	CUSTOM 0 mm ²
9.	R1_S1	Vishay-Dale	CRCW040217K4FKED Series= CRCW..e3	Res= 17.4 kOhm Power= 63.0 mW Tolerance= 1.0%	1	\$0.01	0402 3 mm ²
10.	R1_S2	Vishay-Dale	CRCW04023K92FKED Series= CRCW..e3	Res= 3.92 kOhm Power= 63.0 mW Tolerance= 1.0%	1	\$0.01	0402 3 mm ²
11.	R1_S3	Vishay-Dale	CRCW0402887RFKED Series= CRCW..e3	Res= 887.0 Ohm Power= 63.0 mW Tolerance= 1.0%	1	\$0.01	0402 3 mm ²
12.	R2_S2	Vishay-Dale	CRCW04026K65FKED Series= CRCW..e3	Res= 6.65 kOhm Power= 63.0 mW Tolerance= 1.0%	1	\$0.01	0402 3 mm ²

#	Name	Manufacturer	Part Number	Properties	Qty	Price	Footprint
13.	R2_S3	Vishay-Dale	CRCW04021K15FKED Series= CRCW..e3	Res= 1.15 kOhm Power= 63.0 mW Tolerance= 1.0%	1	\$0.01	0402 3 mm ²

Design Inputs

#	Name	Value	Description
1.	FilterType	Lowpass	
2.	FilterResponse	Chebyshev	
3.	FilterOrder	5.0	
4.	FilterTopology	Sallen_Key	
5.	NumberOfStages	3.0	
6.	PassbandFrequency	2.0 k	
7.	StopbandAttenuation	-45.0	
8.	StopbandFrequency	5.0 k	
9.	Gain	1.0	
10.	DualSupply	+/-5.0 V	Power supply(s) to active chips
11.	ResistorTolerance	E96	Resistor series - 1% Passive resistor tolerance
12.	CapacitorTolerance	E24	Capacitor series - 5% Passive capacitance tolerance
13.	SeedCapacitance	10.0 n	Seed Capacitance to start design of filter

Design Assistance

1. **LF442CN** Product Folder : <http://www.ti.com/product/LF442> : contains the data sheet and other resources.

Filter Stage :1

Cutoff Frequency 922.821 Hz
 Min GBW Req'd 46.141 kHz
 Stage Gain 1.0 V/V
 Stage Q 500.0 m
 Stage Topology Real_Pole

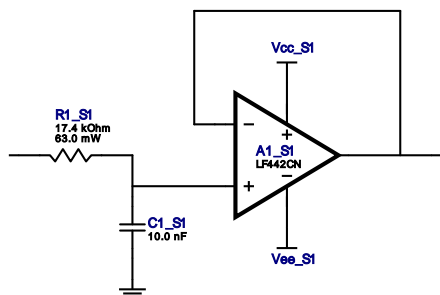

Electrical BOM

#	Name	Manufacturer	Part Number	Properties	Qty	Price	Footprint
1.	A1_S1	Texas Instruments	LF442CN	GbwTyp= 1.0 MHz VccMin= 6.0 V VccMax= 36.0 V	1	\$0.55	DIP 0 mm ²
2.	C1_S1	Kemet	C0603C103J5RACTU Series= X7R	Cap= 10.0 nF VDC= 50.0 V Tolerance= 5.0 %	1	\$0.01	0603 5 mm ²
3.	R1_S1	Vishay-Dale	CRCW040217K4FKED Series= CRCW..e3	Res= 17.4 kOhm Power= 63.0 mW Tolerance= 1.0%	1	\$0.01	0402 3 mm ²

Filter Stage :2

Cutoff Frequency 1.495 kHz
 Min GBW Req'd 149.601 kHz
 Stage Gain 1.0 V/V
 Stage Q 1.001
 Stage Topology Sallen_Key

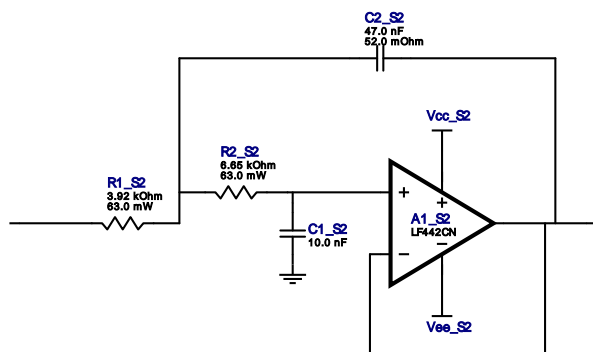

Electrical BOM

#	Name	Manufacturer	Part Number	Properties	Qty	Price	Footprint
1.	A1_S2	Texas Instruments	LF442CN	GbwTyp= 1.0 MHz VccMin= 6.0 V VccMax= 36.0 V	1	\$0.55	DIP 0 mm ²
2.	C1_S2	Kemet	C0603C103J5RACTU Series= X7R	Cap= 10.0 nF VDC= 50.0 V Tolerance= 5.0 %	1	\$0.01	0603 5 mm ²
3.	C2_S2	AVX	06033C473JAT2A Series= X7R	Cap= 47.0 nF ESR= 52.0 mOhm VDC= 25.0 V Tolerance= 5.0 %	1	\$0.09	0603 5 mm ²
4.	R1_S2	Vishay-Dale	CRCW04023K92FKED Series= CRCW..e3	Res= 3.92 kOhm Power= 63.0 mW Tolerance= 1.0%	1	\$0.01	0402 3 mm ²
5.	R2_S2	Vishay-Dale	CRCW04026K65FKED Series= CRCW..e3	Res= 6.65 kOhm Power= 63.0 mW Tolerance= 1.0%	1	\$0.01	0402 3 mm ²

Filter Stage :3

Cutoff Frequency	2.114 kHz
Min GBW Req'd	783.716 kHz
Stage Gain	1.0 V/V
Stage Q	3.707
Stage Topology	Sallen_Key

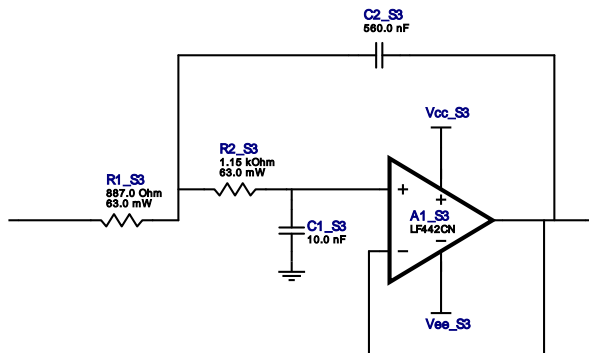

Electrical BOM

#	Name	Manufacturer	Part Number	Properties	Qty	Price	Footprint
1.	A1_S3	Texas Instruments	LF442CN	GbwTyp= 1.0 MHz VccMin= 6.0 V VccMax= 36.0 V	1	\$0.55	DIP 0 mm ²
2.	C1_S3	Kemet	C0603C103J5RACTU Series= X7R	Cap= 10.0 nF VDC= 50.0 V Tolerance= 5.0 %	1	\$0.01	0603 5 mm ²
3.	C2_S3	CUSTOM	CUSTOM Series= ?	Cap= 560.0 nF VDC= 0.0 V Tolerance= 0.0 %	1	NA	CUSTOM 0 mm ²
4.	R1_S3	Vishay-Dale	CRCW0402887RFKED Series= CRCW..e3	Res= 887.0 Ohm Power= 63.0 mW Tolerance= 1.0%	1	\$0.01	0402 3 mm ²
5.	R2_S3	Vishay-Dale	CRCW04021K15FKED Series= CRCW..e3	Res= 1.15 kOhm Power= 63.0 mW Tolerance= 1.0%	1	\$0.01	0402 3 mm ²

Texas Instruments' WEBENCH simulation tools attempt to recreate the performance of a substantially equivalent physical implementation of the design. Simulations are created using Texas Instruments' published specifications as well as the published specifications of other device manufacturers. While Texas Instruments does update this information periodically, this information may not be current at the time the simulation is built. Texas Instruments does not warrant the accuracy or completeness of the specifications or any information contained therein. Texas Instruments does not warrant that any designs or recommended parts will meet the specifications you entered, will be suitable for your application or fit for any particular purpose, or will operate as shown in the simulation in a physical implementation. Texas Instruments does not warrant that the designs are production worthy.

You should completely validate and test your design implementation to confirm the system functionality for your application prior to production.

Use of Texas Instruments' WEBENCH simulation tools is subject to [Texas Instruments' Site Terms and Conditions of Use](#). Prototype boards based on WEBENCH created designs are provided AS IS without warranty of any kind for evaluation and testing purposes and are subject to the terms of the [Evaluation License Agreement](#).