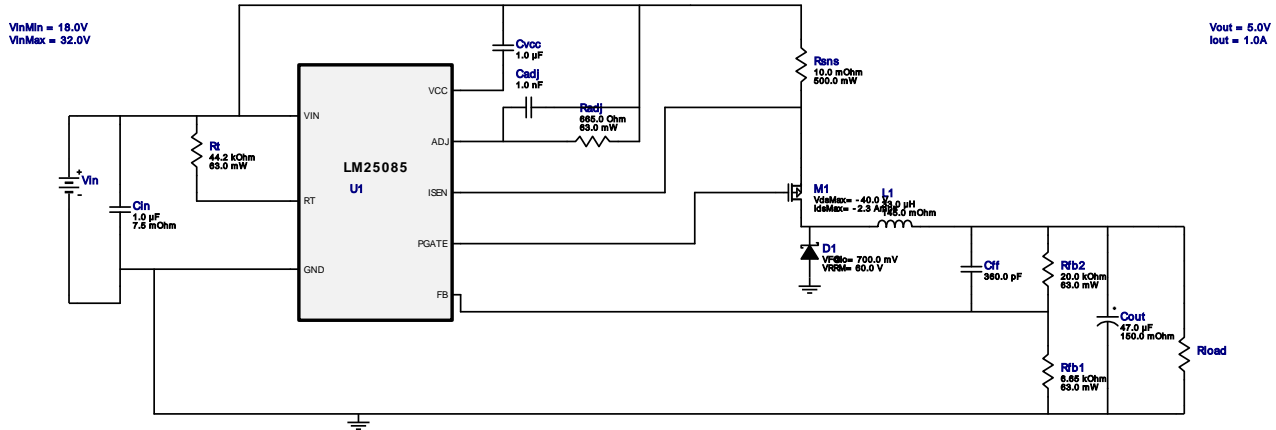
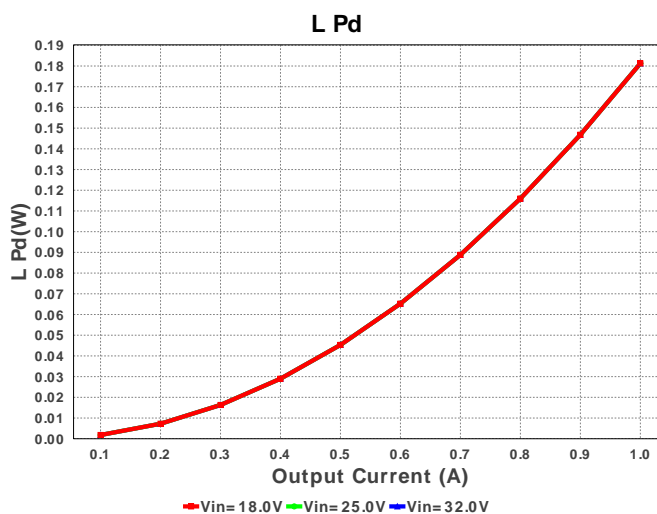
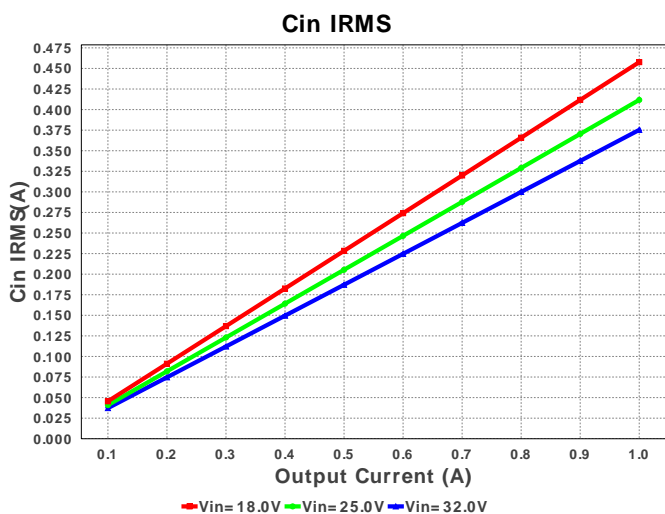
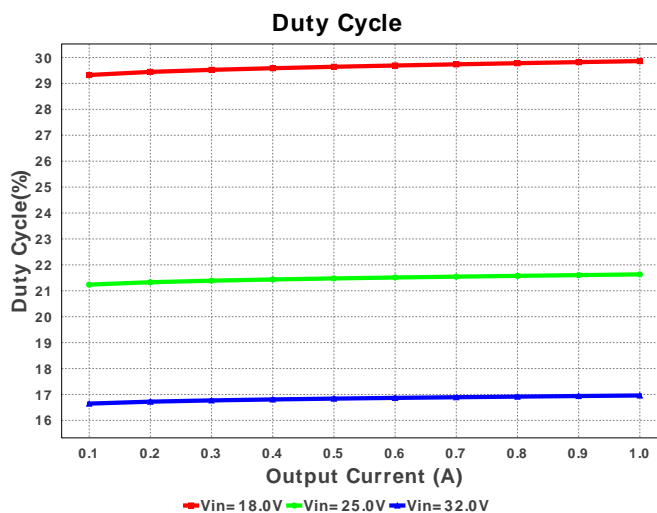
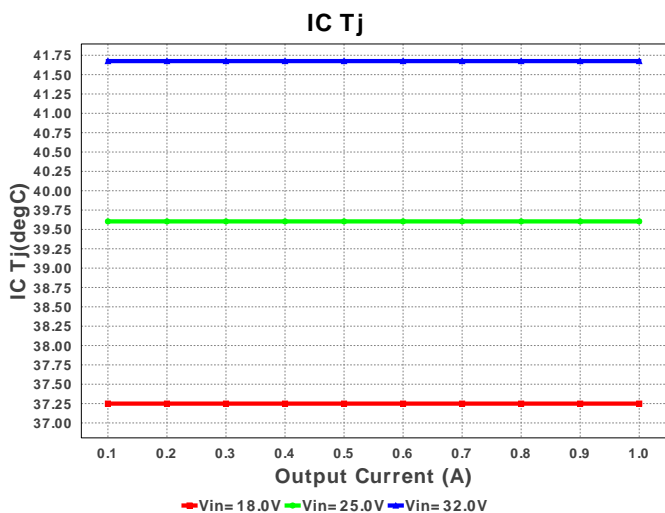

WEBENCH[®] Design Report

 Design : 4425714/5 LM25085MY/NOPB
 LM25085MY/NOPB 18.0V-32.0V to 5.00V @ 1.0A

Electrical BOM

#	Name	Manufacturer	Part Number	Properties	Qty	Price	Footprint
1.	Cadj	Yageo America	CC0805JRNPO9BN102 Series= C0G/NP0	Cap= 1.0 nF VDC= 50.0 V IRMS= 0.0 A	1	\$0.01	 0805 7 mm ²
2.	Cff	MuRata	GRM1555C1H361GA01D Series= C0G/NP0	Cap= 360.0 pF VDC= 50.0 V IRMS= 0.0 A	1	\$0.02	 0402 3 mm ²
3.	Cin	TDK	C3216X7R2A105M160AA Series= X7R	Cap= 1.0 uF ESR= 7.5 mOhm VDC= 100.0 V IRMS= 5.9235 A	1	\$0.11	 1206 11 mm ²
4.	Cout	Panasonic	6TPU47MSI Series= TPU	Cap= 47.0 uF ESR= 150.0 mOhm VDC= 6.3 V IRMS= 510.0 mA	1	\$0.46	 2012-10 7 mm ²
5.	Cvcc	MuRata	GRM21BR61C105KA01L Series= X5R	Cap= 1.0 uF VDC= 16.0 V IRMS= 0.0 A	1	\$0.01	 0805 7 mm ²
6.	D1	Diodes Inc.	B260A-13-F	VF@Io= 700.0 mV VRRM= 60.0 V	1	\$0.09	 SMA 37 mm ²
7.	L1	Bourns	SRN8040-330M	L= 33.0 uH DCR= 145.0 mOhm	1	\$0.22	 SRN8040 100 mm ²
8.	M1	Vishay-Siliconix	SI2319DS-T1-E3	VdsMax= -40.0 V IdsMax= -2.3 Amps	1	\$0.28	 SOT-23 14 mm ²
9.	Radj	Vishay-Dale	CRCW0402665RFKED Series= CRCW..e3	Res= 665.0 Ohm Power= 63.0 mW Tolerance= 1.0%	1	\$0.01	 0402 3 mm ²
10.	Rfb1	Vishay-Dale	CRCW04026K65FKED Series= CRCW..e3	Res= 6.65 kOhm Power= 63.0 mW Tolerance= 1.0%	1	\$0.01	 0402 3 mm ²

#	Name	Manufacturer	Part Number	Properties	Qty	Price	Footprint
11.	Rfb2	Vishay-Dale	CRCW040220K0FKED Series= CRCW..e3	Res= 20.0 kOhm Power= 63.0 mW Tolerance= 1.0%	1	\$0.01	0402 3 mm ²
12.	Rsns	Stackpole Electronics Inc	CSR1206FK10L0 Series= ?	Res= 10.0 mOhm Power= 500.0 mW Tolerance= 1.0%	1	\$0.11	1206 11 mm ²
13.	Rt	Vishay-Dale	CRCW040244K2FKED Series= CRCW..e3	Res= 44.2 kOhm Power= 63.0 mW Tolerance= 1.0%	1	\$0.01	0402 3 mm ²
14.	U1	Texas Instruments	LM25085MY/NOPB	Switcher	1	\$0.70	MUY08A 24 mm ²

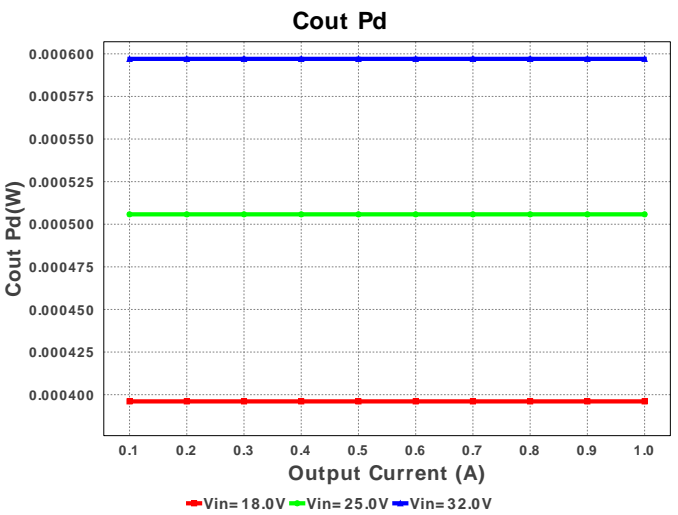
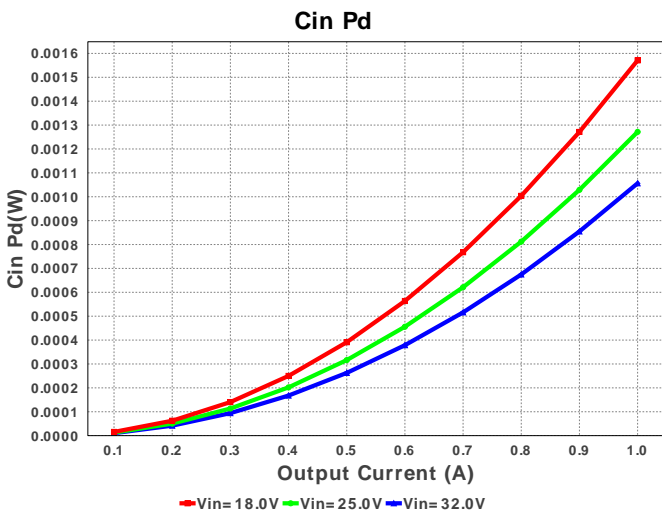
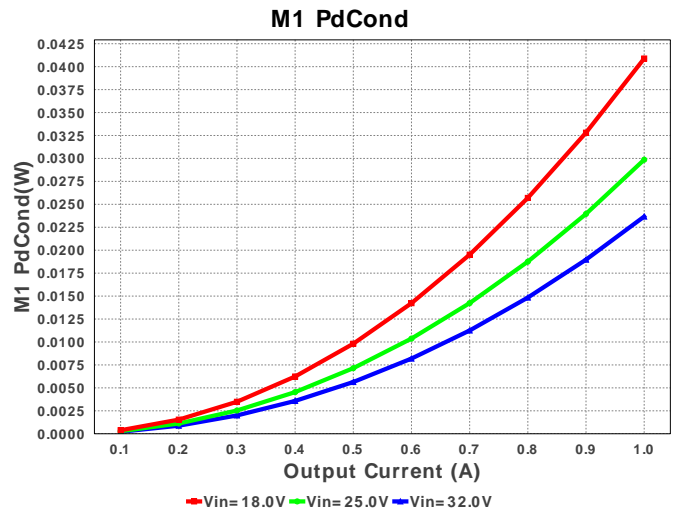
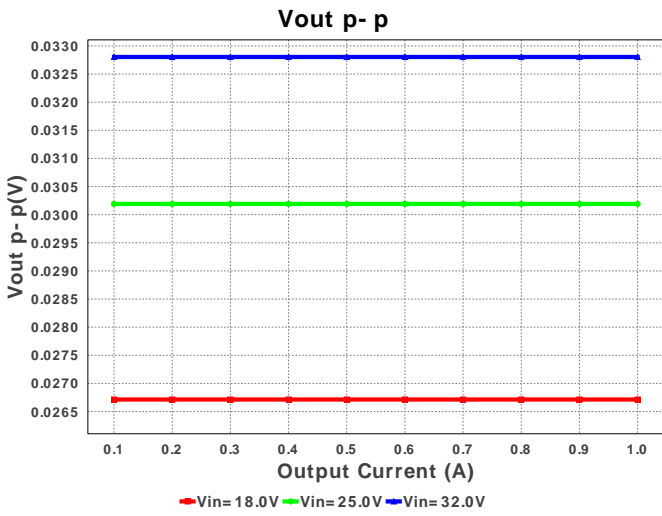
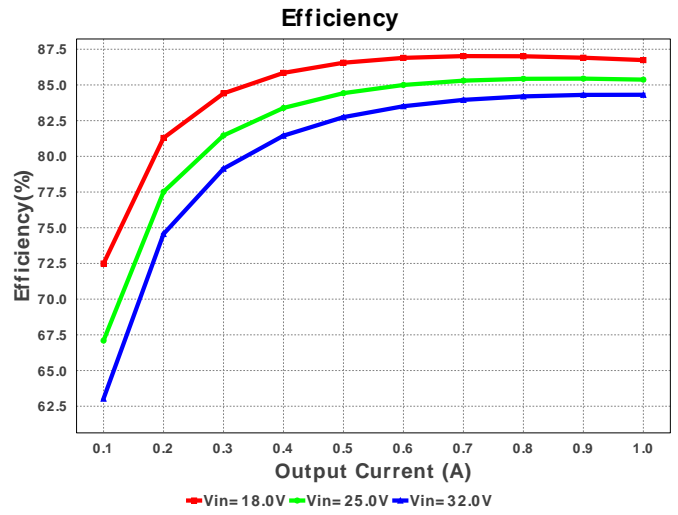
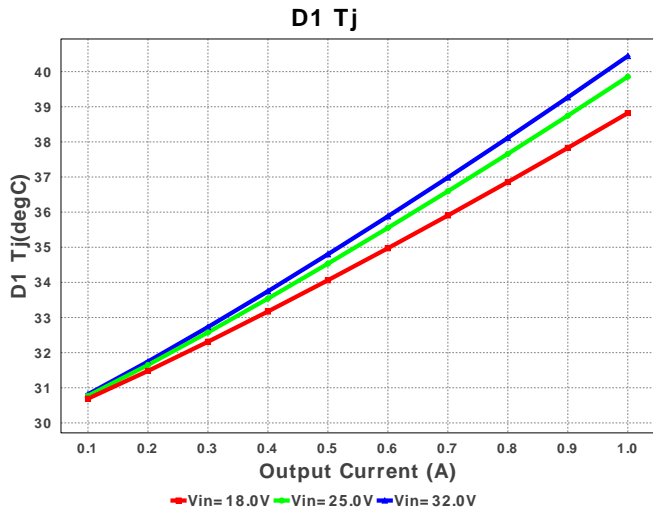

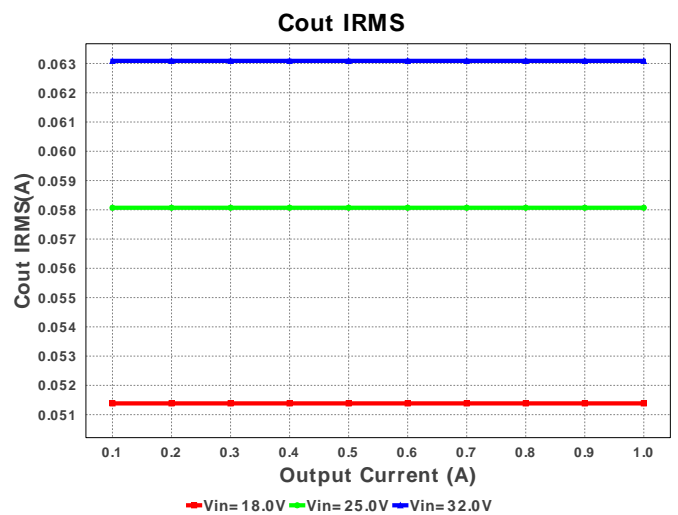
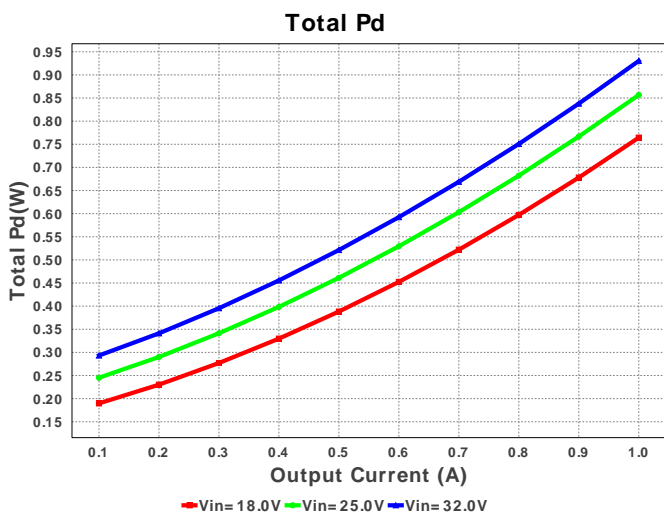
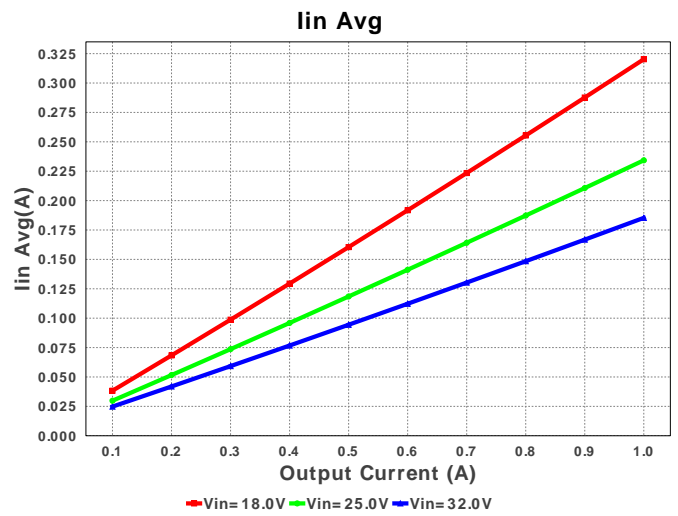
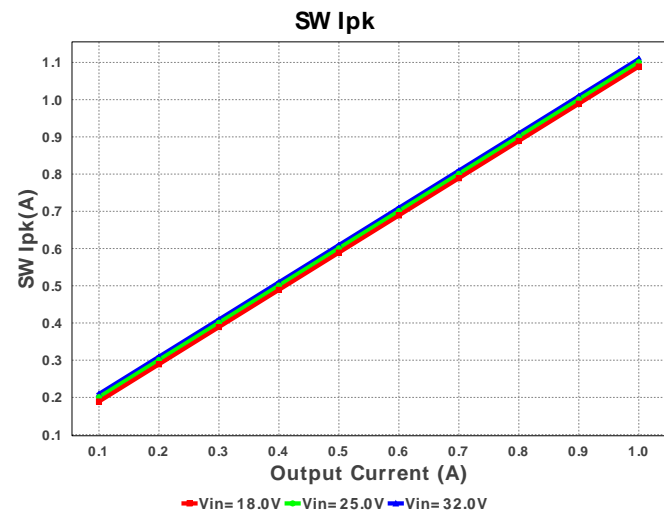
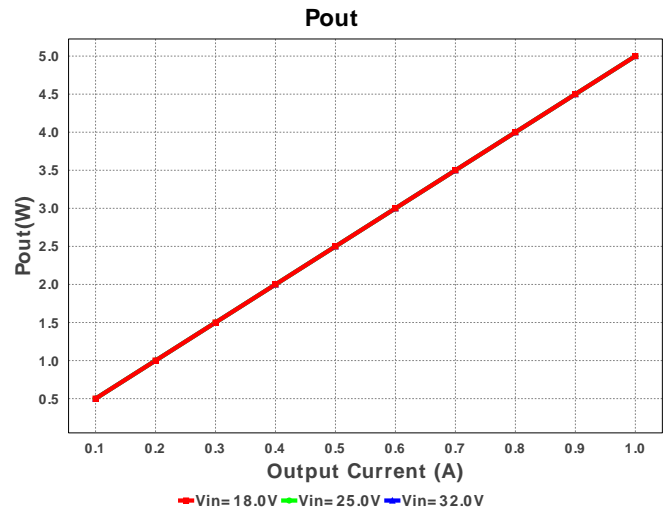
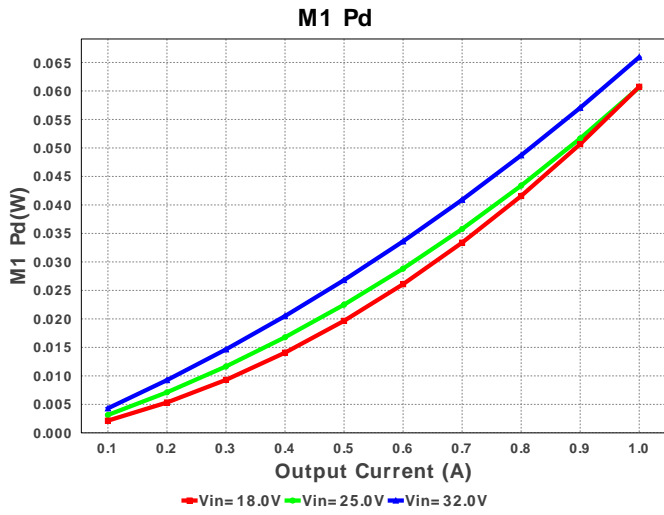



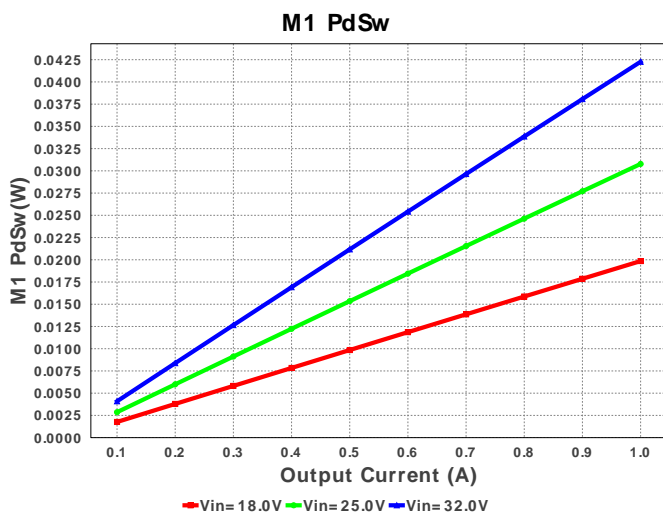
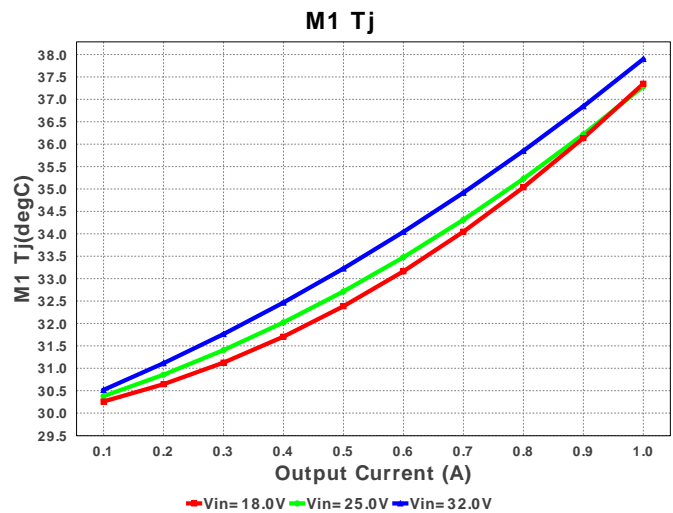
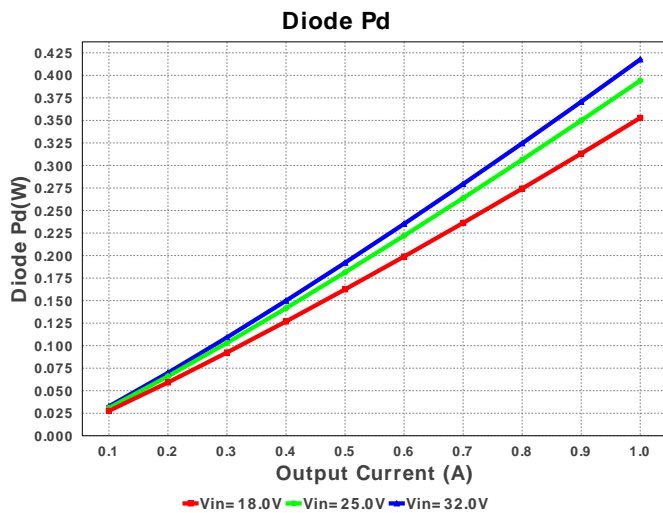
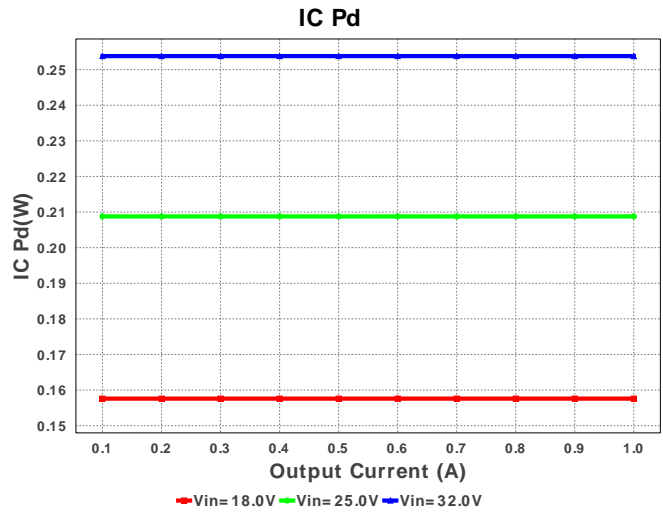
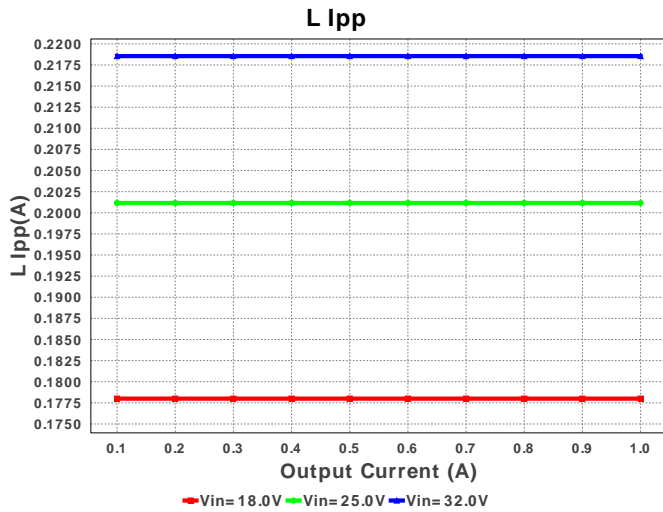

Operating Values

#	Name	Value	Category	Description
1.	Cin IRMS	375.48 mA	Current	Input capacitor RMS ripple current
2.	Cout IRMS	63.089 mA	Current	Output capacitor RMS ripple current
3.	Iin Avg	185.54 mA	Current	Average input current
4.	L Ipp	218.55 mA	Current	Peak-to-peak inductor ripple current
5.	SW Ipk	1.109 A	Current	Peak switch current
6.	BOM Count	14	General	Total Design BOM count
7.	FootPrint	232.0 mm ²	General	Total Foot Print Area of BOM components
8.	Frequency	492.724 kHz	General	Switching frequency
9.	IC Tolerance	25.0 mV	General	IC Feedback Tolerance
10.	Pout	5.0 W	General	Total output power
11.	Total BOM	\$2.05	General	Total BOM Cost

#	Name	Value	Category	Description
12.	D1 Tj	40.617 degC	Op_Point	D1 junction temperature
13.	Vout OP	5.0 V	Op_Point	Operational Output Voltage
14.	Duty Cycle	16.983 %	Op_point	Duty cycle
15.	Efficiency	84.212 %	Op_point	Steady state efficiency
16.	IC Tj	41.675 degC	Op_point	IC junction temperature
17.	ICThetaJA	46.0 degC/W	Op_point	IC junction-to-ambient thermal resistance
18.	IOUT_OP	1.0 A	Op_point	Iout operating point
19.	M1 Tj	37.906 degC	Op_point	M1 MOSFET junction temperature
20.	VIN_OP	32.0 V	Op_point	Vin operating point
21.	Vout p-p	32.803 mV	Op_point	Peak-to-peak output ripple voltage
22.	Cin Pd	1.057 mW	Power	Input capacitor power dissipation
23.	Cout Pd	597.042 μW	Power	Output capacitor power dissipation
24.	Diode Pd	424.675 mW	Power	Diode power dissipation
25.	IC Pd	253.803 mW	Power	IC power dissipation
26.	L Pd	181.25 mW	Power	Inductor power dissipation
27.	M1 Pd	66.005 mW	Power	M1 MOSFET total power dissipation
28.	M1 PdCond	23.724 mW	Power	M1 MOSFET conduction losses
29.	M1 PdSw	42.28 mW	Power	M1 MOSFET switching losses
30.	Total Pd	937.378 mW	Power	Total Power Dissipation

Design Inputs

#	Name	Value	Description
1.	Iout	1.0	Maximum Output Current
2.	Iout1	1.0	Output Current #1
3.	VinMax	32.0	Maximum input voltage
4.	VinMin	18.0	Minimum input voltage
5.	Vout	5.0	Output Voltage
6.	Vout1	5.0	Output Voltage #1
7.	base_pn	LM25085	Texas Instruments Base Part Number
8.	source	DC	Input Source Type
9.	ta	30.0	Ambient temperature

Design Assistance

1. For a Constant On Time device to be stable, we need to provide a ripple at the feedback comparator. There are various methods to implement the ripple. Depending on the circuit complexity vs. the allowable ripple, we have three options to choose from. The simplest option, 'Low Complexity', would require only a high ESR cap at the output. This means that the BOM count will be small, but the output voltage ripple will be quite large. The 'optimal solution' would require a feed-forward cap in parallel with the upper feedback resistor to AC couple the ripple to the feedback node. This increases the BOM count slightly, but now we have more control over the output voltage ripple. If the output voltage requirement is very tight, then the best option is to go for the 'Low Output Ripple' solution. In this option we can go with very low ESR output caps and have very good control over the output voltage ripple

2. LM25085 Product Folder : <http://www.ti.com/product/LM25085> : contains the data sheet and other resources.

Texas Instruments' WEBENCH simulation tools attempt to recreate the performance of a substantially equivalent physical implementation of the design. Simulations are created using Texas Instruments' published specifications as well as the published specifications of other device manufacturers. While Texas Instruments does update this information periodically, this information may not be current at the time the simulation is built. Texas Instruments does not warrant the accuracy or completeness of the specifications or any information contained therein. Texas Instruments does not warrant that any designs or recommended parts will meet the specifications you entered, will be suitable for your application or fit for any particular purpose, or will operate as shown in the simulation in a physical implementation. Texas Instruments does not warrant that the designs are production worthy.

You should completely validate and test your design implementation to confirm the system functionality for your application prior to production.

Use of Texas Instruments' WEBENCH simulation tools is subject to [Texas Instruments' Site Terms and Conditions of Use](#). Prototype boards based on WEBENCH created designs are provided AS IS without warranty of any kind for evaluation and testing purposes and are subject to the terms of the [Evaluation License Agreement](#).