

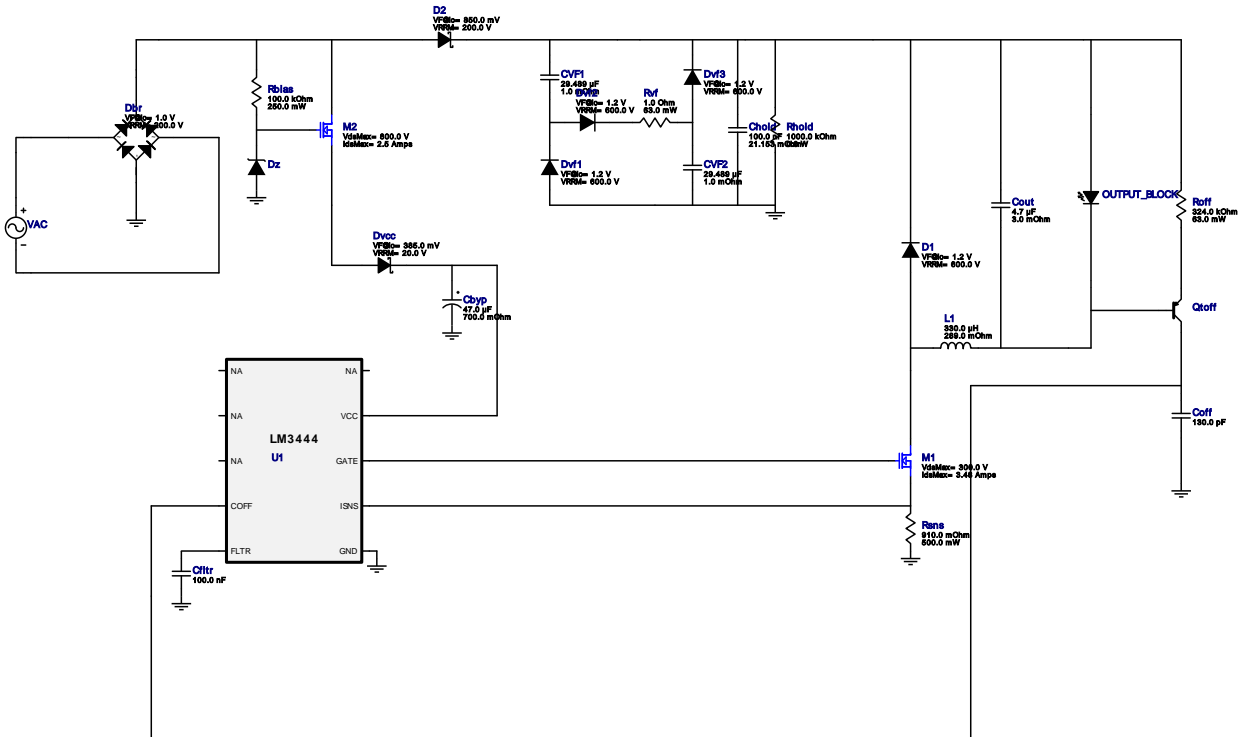



WEBENCH[®] Design Report

 Design : 4407031/31 LM3444MM/NOPB
 LM3444MM/NOPB 100.0V-120.0V to 41.90V @ 0.7A

Electrical BOM

#	Name	Manufacturer	Part Number	Properties	Qty	Price	Footprint
1.	CVF1	CUSTOM	CUSTOM Series= ?	Cap= 29.489 uF ESR= 1.0 mOhm VDC= 135.765 V IRMS= 1.08078 A	1	NA	CUSTOM 0 mm ²
2.	CVF2	CUSTOM	CUSTOM Series= ?	Cap= 29.489 uF ESR= 1.0 mOhm VDC= 135.765 V IRMS= 1.08078 A	1	NA	CUSTOM 0 mm ²
3.	Cbyp	Panasonic	EEE-FK1C470UR Series= FK	Cap= 47.0 uF ESR= 700.0 mOhm VDC= 16.0 V IRMS= 160.0 mA	1	\$0.11	 SM_RADIAL_C 62 mm ²
4.	Cfilt	MuRata	GRM21BR71E104KA01L Series= X7R	Cap= 100.0 nF VDC= 25.0 V IRMS= 0.0 A	1	\$0.01	 0805 7 mm ²
5.	Chold	TDK	C3216JB2E104K Series= JB	Cap= 100.0 nF ESR= 21.153 mOhm VDC= 250.0 V IRMS= 0.0 A	1	\$0.07	 1206 11 mm ²
6.	Coff	MuRata	GRM1555C1H131JA01D Series= C0G/NP0	Cap= 130.0 pF VDC= 50.0 V IRMS= 0.0 A	1	\$0.01	 0402 3 mm ²
7.	Cout	MuRata	GRM31CR71H475KA12L Series= X7R	Cap= 4.7 uF ESR= 3.0 mOhm VDC= 50.0 V IRMS= 4.98 A	1	\$0.07	 1206 11 mm ²

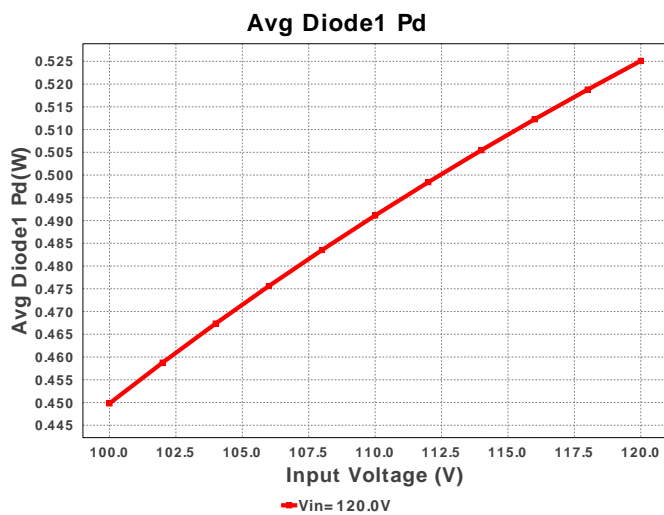
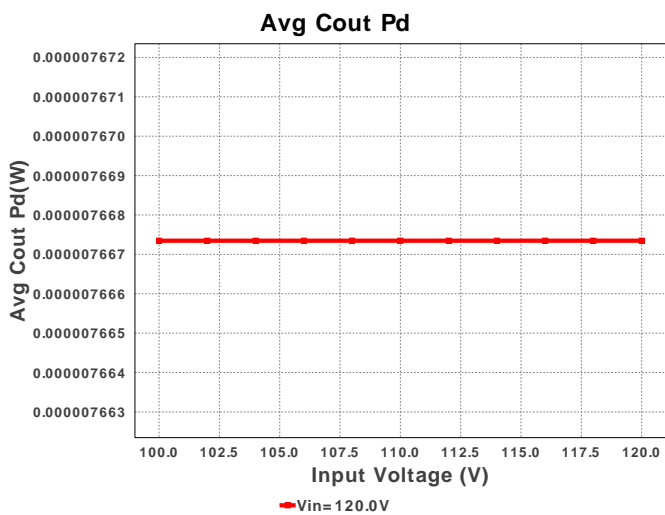
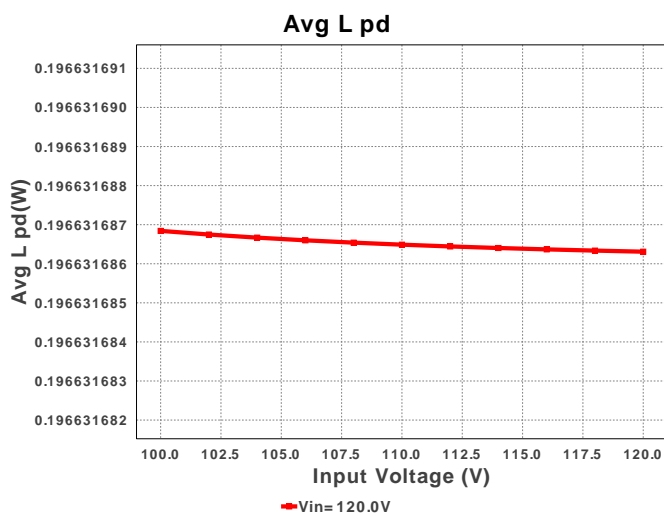
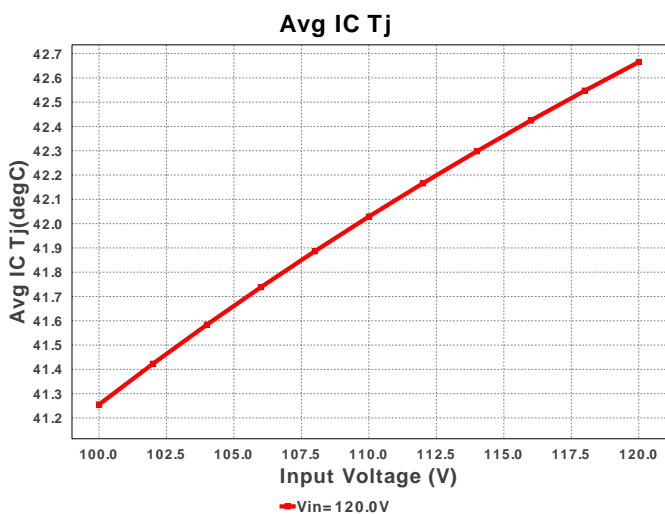
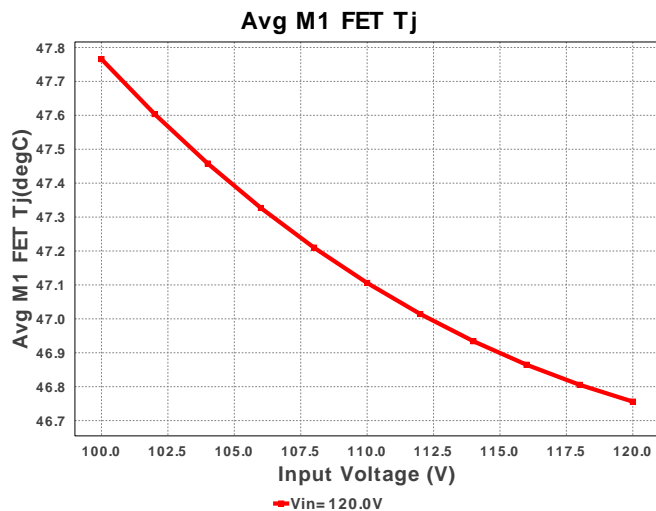
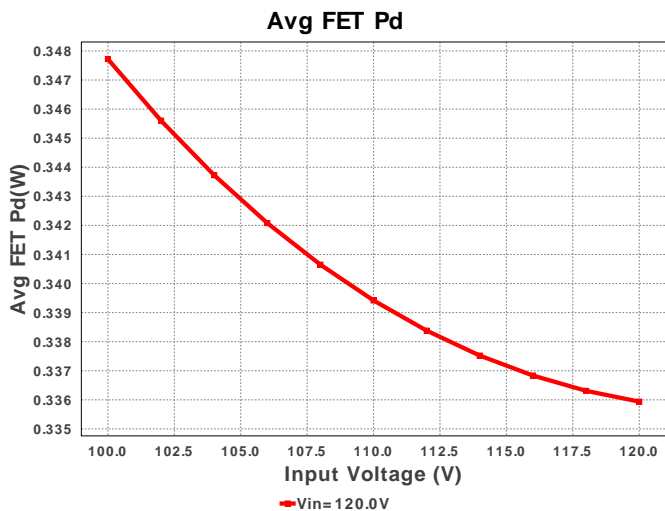
#	Name	Manufacturer	Part Number	Properties	Qty	Price	Footprint
8.	D1	Bourns	CD214B-F3600	VF@Io= 1.2 V VRRM= 600.0 V	1	\$0.14	 SMB 44 mm ²
9.	D2	Diodes Inc.	DFLS1200-7	VF@Io= 850.0 mV VRRM= 200.0 V	1	\$0.21	 PowerDI123 13 mm ²
10.	D_LED	Cree	XHP50A-00-0000-0D0BJ40DLED		2	\$6.35	 xlampxhp 0 mm ²
11.	Dbr	Diodes Inc.	HD02-T	VF@Io= 1.0 V VRRM= 200.0 V	1	\$0.12	 MiniDIP 62 mm ²
12.	Dvcc	ON Semiconductor	MBR0520LT1G	VF@Io= 385.0 mV VRRM= 20.0 V	1	\$0.06	 SOD-123 13 mm ²
13.	Dvf1	Bourns	CD214B-F3600	VF@Io= 1.2 V VRRM= 600.0 V	1	\$0.14	 SMB 44 mm ²
14.	Dvf2	Bourns	CD214B-F3600	VF@Io= 1.2 V VRRM= 600.0 V	1	\$0.14	 SMB 44 mm ²
15.	Dvf3	Bourns	CD214B-F3600	VF@Io= 1.2 V VRRM= 600.0 V	1	\$0.14	 SMB 44 mm ²
16.	Dz	ON Semiconductor	BZX84C15LT1G	Zener	1	\$0.02	 SOT-23 14 mm ²
17.	L1	Coilcraft	MSS1210-334KEB	L= 330.0 µH DCR= 289.0 mOhm	1	\$0.81	 MSS1210 204 mm ²
18.	M1	Fairchild Semiconductor	FQD7N30TM	VdsMax= 300.0 V IdsMax= 3.48 Amps	1	\$0.40	 DPAK 102 mm ²
19.	M2	STMicroelectronics	STD3NK80ZT4	VdsMax= 800.0 V IdsMax= 2.5 Amps	1	\$0.46	 DPAK 102 mm ²
20.	Qtoff	Fairchild Semiconductor	MMBTA92	Bipolar Transistor	1	\$0.05	 SOT-23 14 mm ²
21.	Rbias	Panasonic	ERJ-8ENF1003V Series= ERJ-8E	Res= 100.0 kOhm Power= 250.0 mW Tolerance= 1.0%	1	\$0.01	 1206 11 mm ²
22.	Rhold	CUSTOM	CUSTOM Series= ?	Res= 1000.0 kOhm Power= 0.0 W Tolerance= 0.0%	1	NA	CUSTOM 0 mm ²
23.	Roff	Vishay-Dale	CRCW0402324KFKED Series= CRCW..e3	Res= 324.0 kOhm Power= 63.0 mW Tolerance= 1.0%	1	\$0.01	 0402 3 mm ²
24.	Rsns	Bourns	CRM1206-FX-R910ELF Series= ?	Res= 910.0 mOhm Power= 500.0 mW Tolerance= 1.0%	1	\$0.03	 1206 11 mm ²
25.	Rvf	Vishay-Dale	CRCW04021R00FKED Series= CRCW..e3	Res= 1.0 Ohm Power= 63.0 mW Tolerance= 1.0%	1	\$0.01	 0402 3 mm ²
26.	U1	Texas Instruments	LM3444MM/NOPB	Switcher	1	\$0.55	0 mm ²

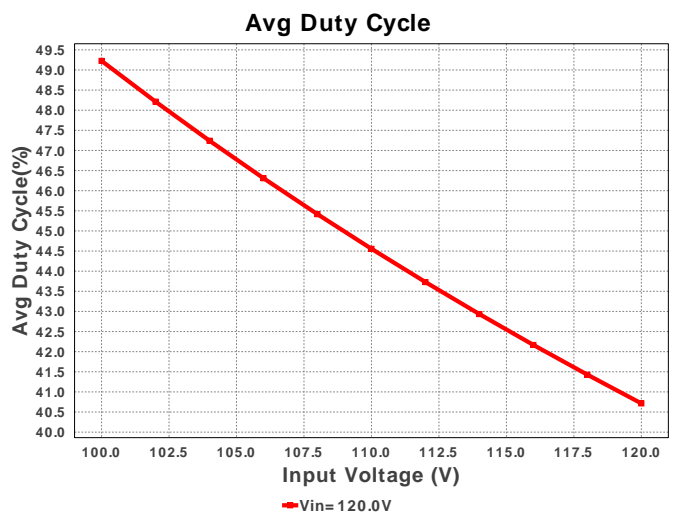
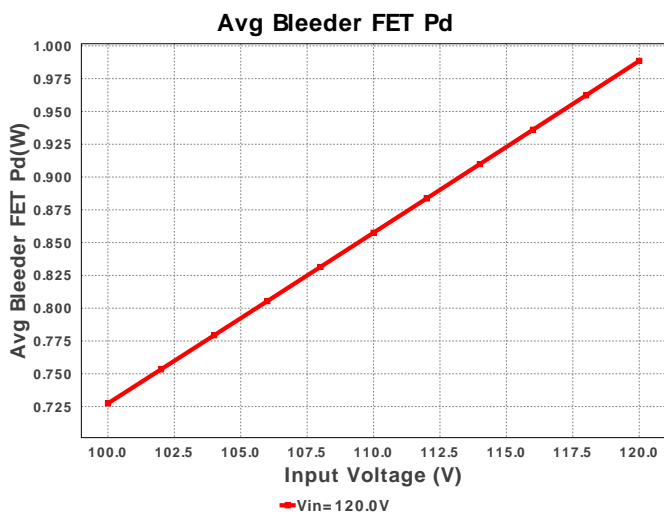
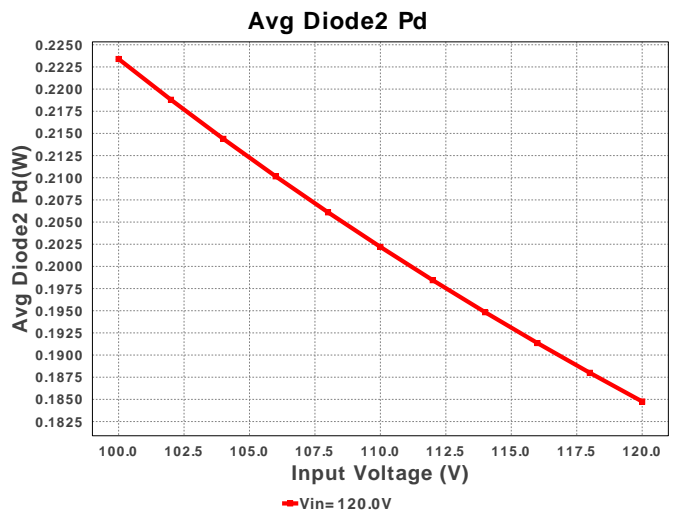
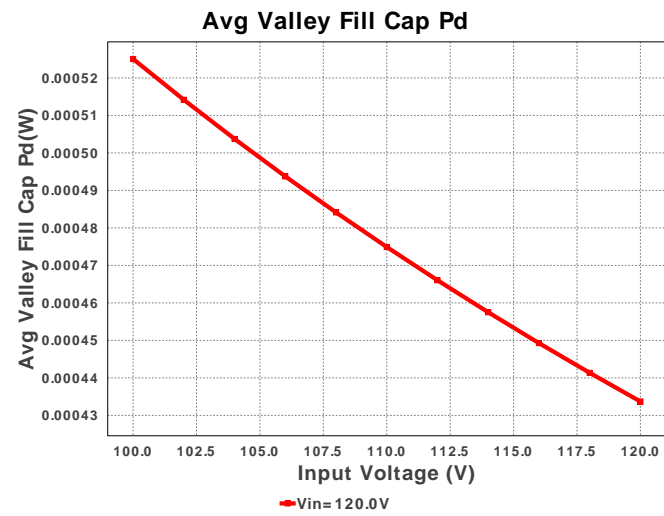
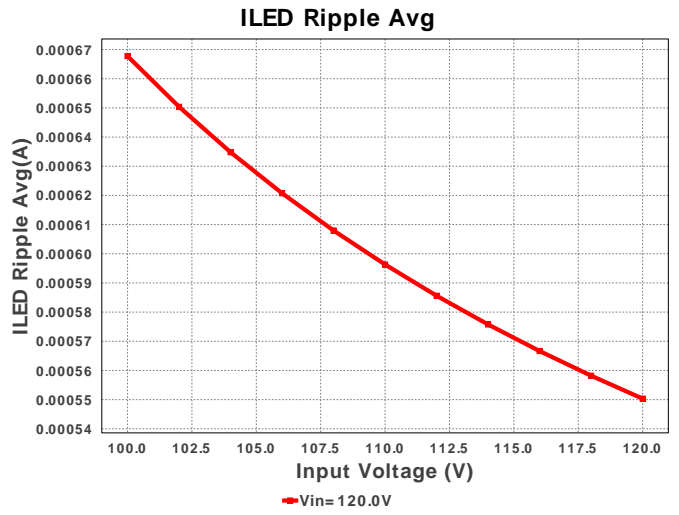
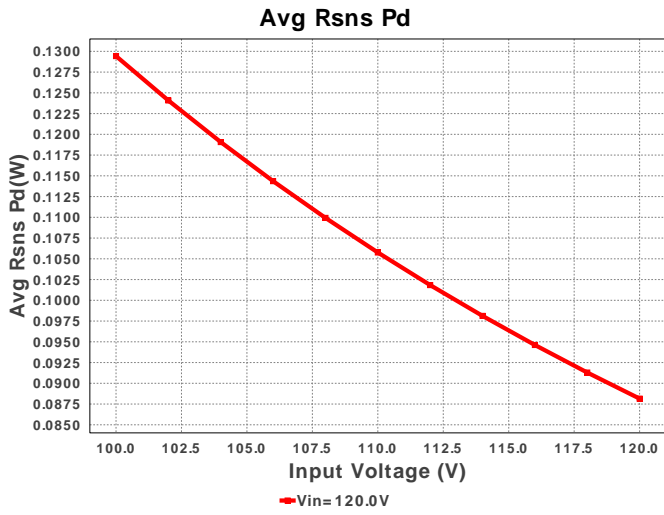

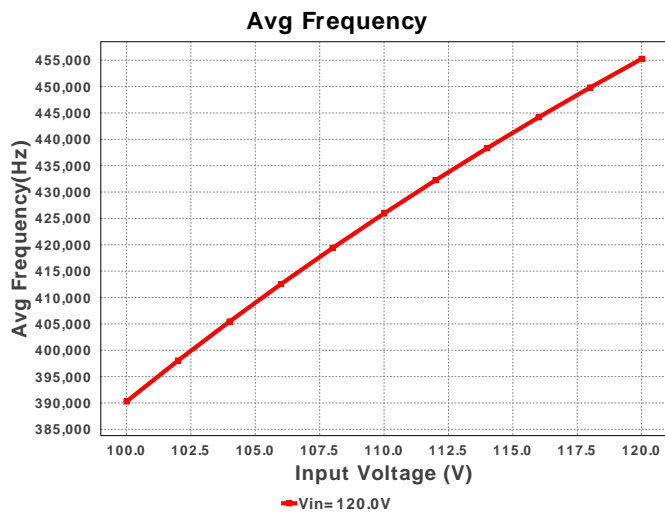
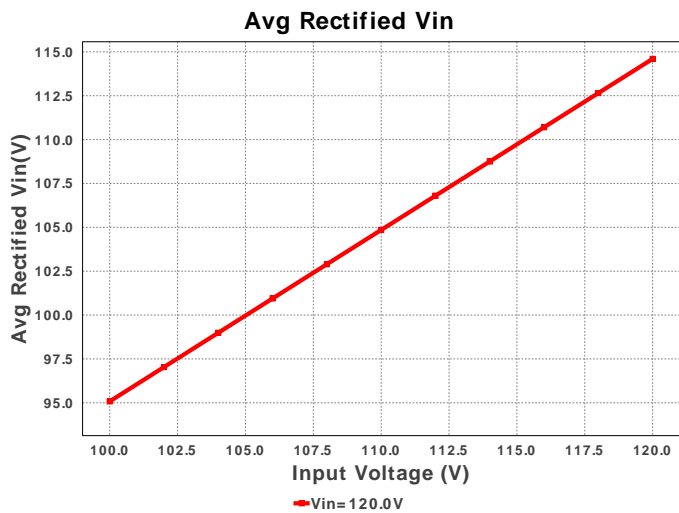
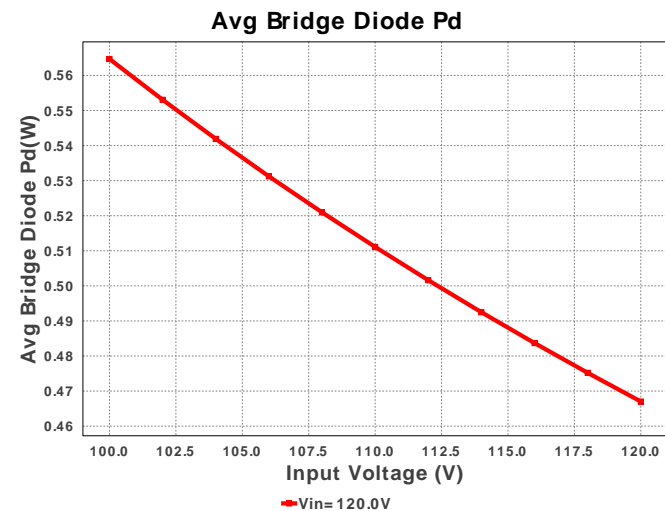
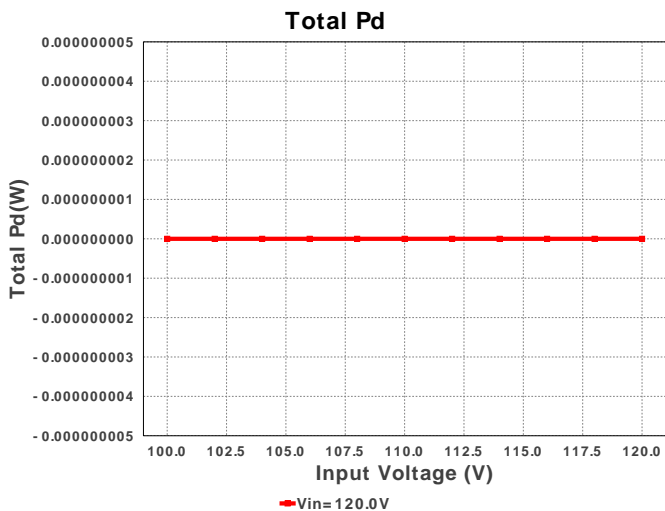
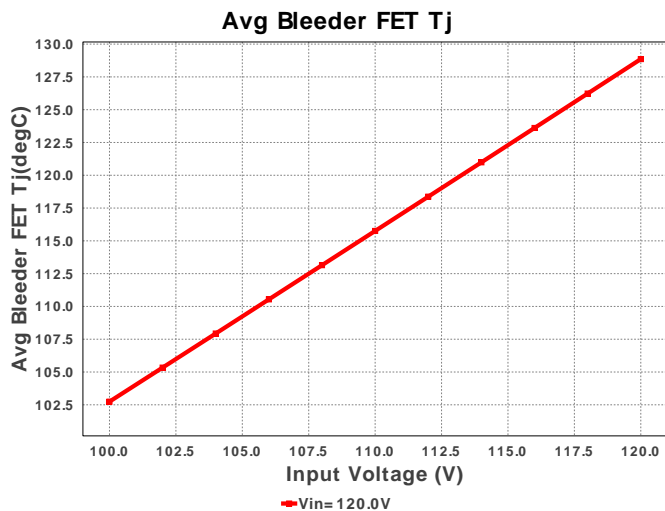
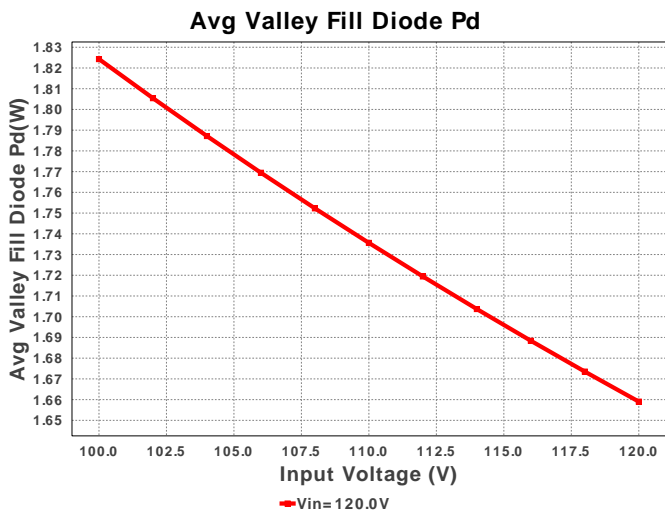



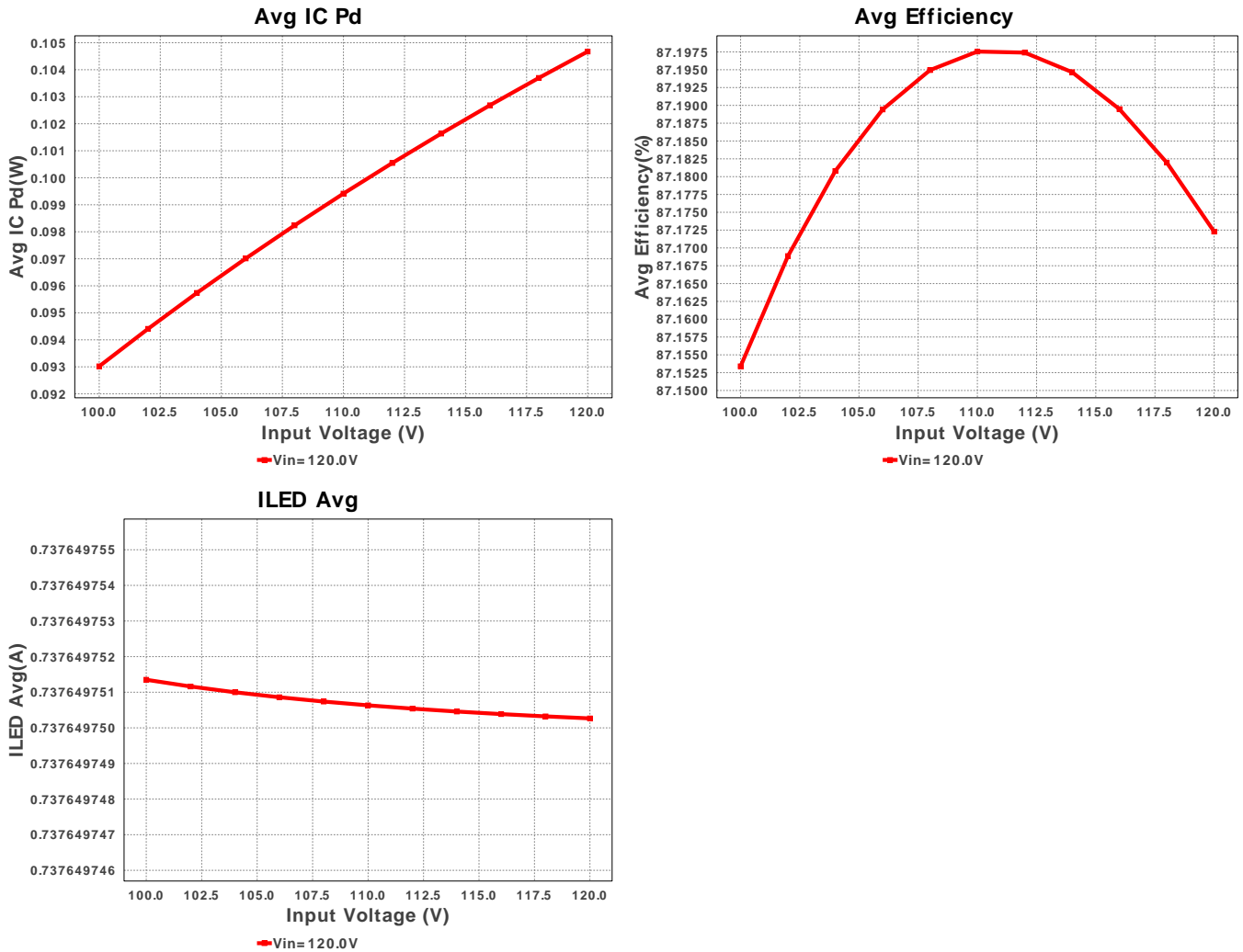

Operating Values

#	Name	Value	Category	Description
1.	ILED Avg	737.65 mA	Current	Average Current per LED for the AC line period
2.	ILED Ripple Avg	550.471 μ A	Current	Average LED Ripple Current for the AC line period
3.	Avg Rectified Vin	114.599 V	General	Average Rectified Voltage for the AC Line Period
4.	BOM Count	27	General	Total Design BOM count
5.	FootPrint	862.0 mm ²	General	Total Foot Print Area of BOM components
6.	Total BOM	\$0.0	General	Total BOM Cost
7.	Avg Bleeder FET Tj	128.846 degC	Op_Point	Bleeder MOSFET average junction temperature over the AC Line Period
8.	Avg M1 FET Tj	46.758 degC	Op_Point	M1 MOSFET average junction temperature over the AC Line Period
9.	Avg Duty Cycle	40.725 %	Op_point	Average Duty Cycle over the AC Line Period
10.	Avg Efficiency	87.186 %	Op_point	Average Efficiency over the AC Line Period
11.	Avg Frequency	455.178 kHz	Op_point	Average Switching Frequency over the AC Line Period
12.	Avg IC Tj	42.664 degC	Op_point	Average IC junction temperature for the AC line period
13.	VIN_OP	120.0 V	Op_point	AC Input RMS Voltage
14.	Avg Bleeder FET Pd	988.464 mW	Power	Average power dissipation in the bleeder FET over the AC line period
15.	Avg Bridge Diode Pd	449.135 mW	Power	Average Power Dissipation in the Bridge Diode over the AC Line Period
16.	Avg Cout Pd	7.667 μ W	Power	Average Power Dissipation in the Output Capacitor over the AC Line Period
17.	Avg Diode1 Pd	525.011 mW	Power	Average Power Dissipation in D1 over the AC Line Period
18.	Avg Diode2 Pd	184.807 mW	Power	Average Power Dissipation in D1 over the AC Line Period
19.	Avg FET Pd	348.406 mW	Power	Average power dissipation in the switching FET over the AC line period
20.	Avg IC Pd	104.659 mW	Power	Average Power Dissipation in the IC over the AC line period
21.	Avg L pd	196.632 mW	Power	Average Inductor power dissipation over the AC line period
22.	Avg Rsns Pd	88.202 mW	Power	Average power dissipation in the Current limit resistor over the AC line period
23.	Avg Valley Fill Cap Pd	433.707 μ W	Power	Average Power Dissipation in the Valley Fill Capacitors over the AC Line Period
24.	Avg Valley Fill Diode Pd	1.659 W	Power	Average Power Dissipation in the Valley Fill Diodes over the AC Line Period
25.	Total Pd	0.0 W	Power	Total Power Dissipation

Design Inputs

#	Name	Value	Description
1.	Iout	700.0 m	Maximum Output Current
2.	Iout1	700.0 m	Output Current #1
3.	VinMax	120.0	Maximum input voltage
4.	VinMin	100.0	Minimum input voltage
5.	Vout	23.0	Output Voltage
6.	Vout1	23.0	Output Voltage #1
7.	acFrequency	50.0	Light Output in Lumen
8.	application	LED_DRIVER	LED Application
9.	base_pn	LM3444	Texas Instruments Base Part Number
10.	isLEDArchitect	N	LED Architect Project
11.	ledparallel	1.0	Number of LED in parallel
12.	ledpartnumber	XHP50A-00-0000-0D0B140P	LED Part number
13.	ledseries	2.0	Number of LED in series
14.	line_fsw	50.0	AC Line Frequency
15.	source	AC	Input Source Type
16.	ta	30.0	Ambient temperature

Design Assistance

1. LM3444 Product Folder : <http://www.ti.com/product/LM3444> : contains the data sheet and other resources.

Texas Instruments' WEBENCH simulation tools attempt to recreate the performance of a substantially equivalent physical implementation of the design. Simulations are created using Texas Instruments' published specifications as well as the published specifications of other device manufacturers. While Texas Instruments does update this information periodically, this information may not be current at the time the simulation is built. Texas Instruments does not warrant the accuracy or completeness of the specifications or any information contained therein. Texas Instruments does not warrant that any designs or recommended parts will meet the specifications you entered, will be suitable for your application or fit for any particular purpose, or will operate as shown in the simulation in a physical implementation. Texas Instruments does not warrant that the designs are production worthy.

You should completely validate and test your design implementation to confirm the system functionality for your application prior to production.

Use of Texas Instruments' WEBENCH simulation tools is subject to [Texas Instruments' Site Terms and Conditions of Use](#). Prototype boards based on WEBENCH created designs are provided AS IS without warranty of any kind for evaluation and testing purposes and are subject to the terms of the [Evaluation License Agreement](#).