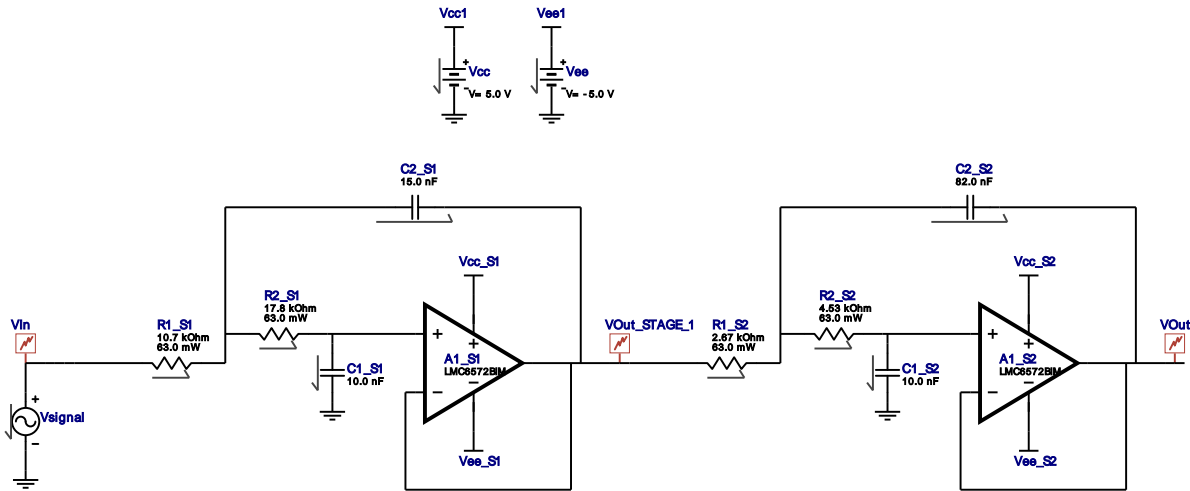

WEBENCH® Electrical Simulation Report

Electrical BOM

#	Name	Manufacturer	Part Number	Properties	Qty	Price	Footprint
1.	A1_S1	Texas Instruments	LMC6572BIM	GbwTyp= 220.0 mMHz VccMin= 2.7 V VccMax= 10.0 V	1	\$0.55	SOIC 0 mm ²
2.	A1_S2	Texas Instruments	LMC6572BIM	GbwTyp= 220.0 mMHz VccMin= 2.7 V VccMax= 10.0 V	1	\$0.55	SOIC 0 mm ²
3.	C1_S1	Kemet	C0603C103J5RACTU Series= X7R	Cap= 10.0 nF VDC= 50.0 V IRMS= 0.0 A	1	\$0.01	0603 5 mm ²
4.	C1_S2	Kemet	C0603C103J5RACTU Series= X7R	Cap= 10.0 nF VDC= 50.0 V IRMS= 0.0 A	1	\$0.01	0603 5 mm ²
5.	C2_S1	Kemet	C0603C153G4GAC7867 Series= C0G/NP0	Cap= 15.0 nF VDC= 16.0 V IRMS= 0.0 A	1	\$0.21	0603 5 mm ²
6.	C2_S2	AVX	12063A822JAT2A Series= C0G/NP0	Cap= 82.0 nF VDC= 25.0 V IRMS= 0.0 A	1	\$0.14	1206 11 mm ²
7.	R1_S1	Vishay-Dale	CRCW040210K7FKED Series= CRCW..e3	Res= 10.7 kOhm Power= 63.0 mW Tolerance= 1.0%	1	\$0.01	0402 3 mm ²
8.	R1_S2	Vishay-Dale	CRCW04022K67FKED Series= CRCW..e3	Res= 2.67 kOhm Power= 63.0 mW Tolerance= 1.0%	1	\$0.01	0402 3 mm ²
9.	R2_S1	Vishay-Dale	CRCW040217K8FKED Series= CRCW..e3	Res= 17.8 kOhm Power= 63.0 mW Tolerance= 1.0%	1	\$0.01	0402 3 mm ²
10.	R2_S2	Vishay-Dale	CRCW04024K53FKED Series= CRCW..e3	Res= 4.53 kOhm Power= 63.0 mW Tolerance= 1.0%	1	\$0.01	0402 3 mm ²

Simulation Parameters

#	Name	Parameter Name	Description	Values
1.	Vsignal	AC	AC Voltage Source Amplitude	1 V
		DC	AC Voltage Source DC Offset	0.0 V

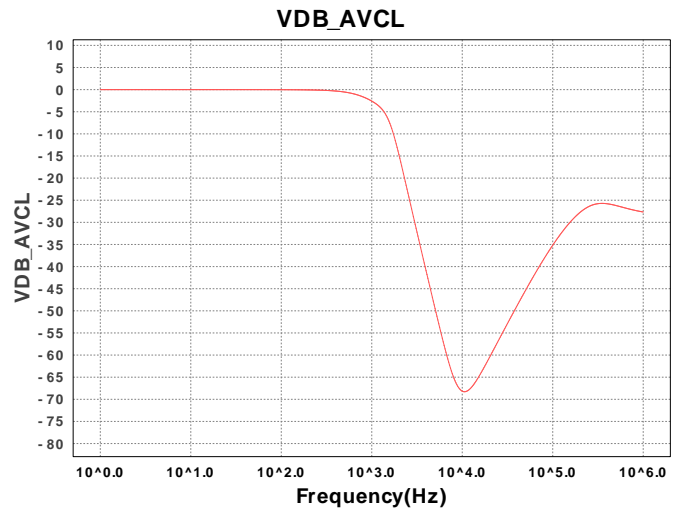
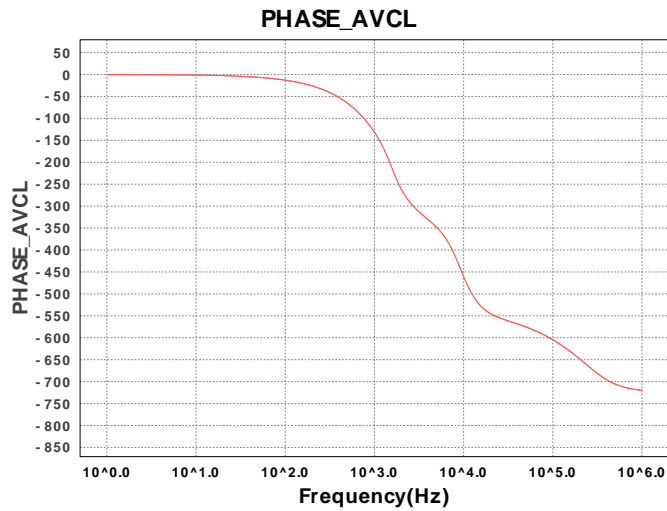
#	Name	Parameter Name	Description	Values
2.	Vcc	V	Vcc Supply Rail Value	5.0 V
3.	Vee	V	Vee Supply Rail Value	-5.0 V



Design Inputs

#	Name	Value	Description
1.	FilterType	Lowpass	
2.	FilterResponse	Gaussian_6dB	
3.	FilterOrder	4.0	
4.	FilterTopology	Sallen_Key	
5.	NumberOfStages	2.0	
6.	PassbandFrequency	1,000 Hz	
7.	StopbandAttenuation	-45.0 dB	
8.	StopbandFrequency	5.0 kHz	
9.	Gain	1.0 V/V	
10.	DualSupply	+/-5.0 V	Power supply(s) to active chips
11.	ResistorTolerance	E96	Resistor series - 1% Passive resistor tolerance
12.	CapacitorTolerance	E24	Capacitor series - 5% Passive capacitance tolerance
13.	SeedCapacitance	10.0 nF	Seed Capacitance to start design of filter

Design Assistance

1. **LMC6572BIM** Product Folder : <http://www.ti.com/product/LMC6572> : contains the data sheet and other resources.

Filter Stage :1

Cutoff Frequency 940.0 Hz
 Min GBW Req'd 55.46 kHz
 Stage Gain 1.0 V/V
 Stage Q 590.0 m
 Stage Topology Sallen_Key

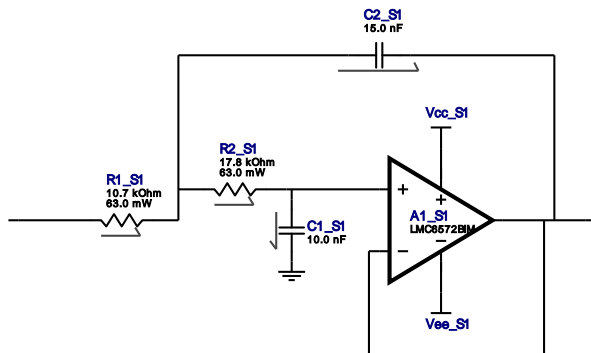

Electrical BOM

#	Name	Manufacturer	Part Number	Properties	Qty	Price	Footprint
1.	A1_S1	Texas Instruments	LMC6572BIM	GbwTyp= 220.0 mMHz VccMin= 2.7 V VccMax= 10.0 V	1	\$0.55	SOIC 0 mm ²
2.	C1_S1	Kemet	C0603C103J5RACTU Series= X7R	Cap= 10.0 nF VDC= 50.0 V IRMS= 0.0 A	1	\$0.01	0603 5 mm ²
3.	C2_S1	Kemet	C0603C153G4GAC7867 Series= C0G/NP0	Cap= 15.0 nF VDC= 16.0 V IRMS= 0.0 A	1	\$0.21	0603 5 mm ²
4.	R1_S1	Vishay-Dale	CRCW040210K7FKED Series= CRCW..e3	Res= 10.7 kOhm Power= 63.0 mW Tolerance= 1.0%	1	\$0.01	0402 3 mm ²
5.	R2_S1	Vishay-Dale	CRCW040217K8FKED Series= CRCW..e3	Res= 17.8 kOhm Power= 63.0 mW Tolerance= 1.0%	1	\$0.01	0402 3 mm ²

Filter Stage :2

Cutoff Frequency	1.665 kHz
Min GBW Req'd	219.78 kHz
Stage Gain	1.0 V/V
Stage Q	1.32
Stage Topology	Sallen_Key

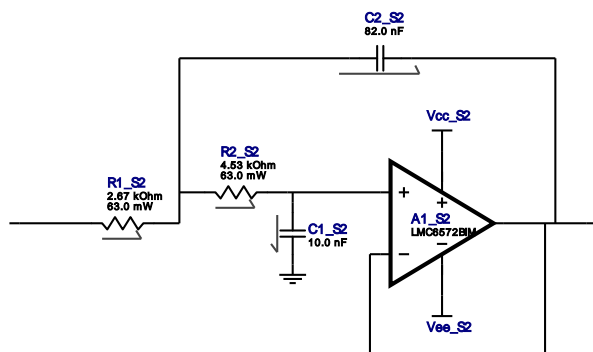

Electrical BOM

#	Name	Manufacturer	Part Number	Properties	Qty	Price	Footprint
1.	A1_S2	Texas Instruments	LMC6572BIM	GbwTyp= 220.0 mMHz VccMin= 2.7 V VccMax= 10.0 V	1	\$0.55	SOIC 0 mm ²
2.	C1_S2	Kemet	C0603C103J5RACTU Series= X7R	Cap= 10.0 nF VDC= 50.0 V IRMS= 0.0 A	1	\$0.01	0603 5 mm ²
3.	C2_S2	AVX	12063A822JAT2A Series= C0G/NP0	Cap= 82.0 nF VDC= 25.0 V IRMS= 0.0 A	1	\$0.14	1206 11 mm ²
4.	R1_S2	Vishay-Dale	CRCW04022K67FKED Series= CRCW..e3	Res= 2.67 kOhm Power= 63.0 mW Tolerance= 1.0%	1	\$0.01	0402 3 mm ²
5.	R2_S2	Vishay-Dale	CRCW04024K53FKED Series= CRCW..e3	Res= 4.53 kOhm Power= 63.0 mW Tolerance= 1.0%	1	\$0.01	0402 3 mm ²

Texas Instruments' WEBENCH simulation tools attempt to recreate the performance of a substantially equivalent physical implementation of the design. Simulations are created using Texas Instruments' published specifications as well as the published specifications of other device manufacturers. While Texas Instruments does update this information periodically, this information may not be current at the time the simulation is built. Texas Instruments does not warrant the accuracy or completeness of the specifications or any information contained therein. Texas Instruments does not warrant that any designs or recommended parts will meet the specifications you entered, will be suitable for your application or fit for any particular purpose, or will operate as shown in the simulation in a physical implementation. Texas Instruments does not warrant that the designs are production worthy.

You should completely validate and test your design implementation to confirm the system functionality for your application prior to production.

Use of Texas Instruments' WEBENCH simulation tools is subject to [Texas Instruments' Site Terms and Conditions of Use](#). Prototype boards based on WEBENCH created designs are provided AS IS without warranty of any kind for evaluation and testing purposes and are subject to the terms of the [Evaluation License Agreement](#).